

1. Install the ice maker properly in accordance with the instructions on location, water supply/drain connections and electrical connections stated in the instruction and installation manuals provided. Allow 10mm extra space at the installation site to meet any installation requirements (additional spacing is also required for proper air flow and pipe connections).
2. The ice production depends on the ambient and water temperatures. Refer to the instruction manual.
3. Product code: M034-C105

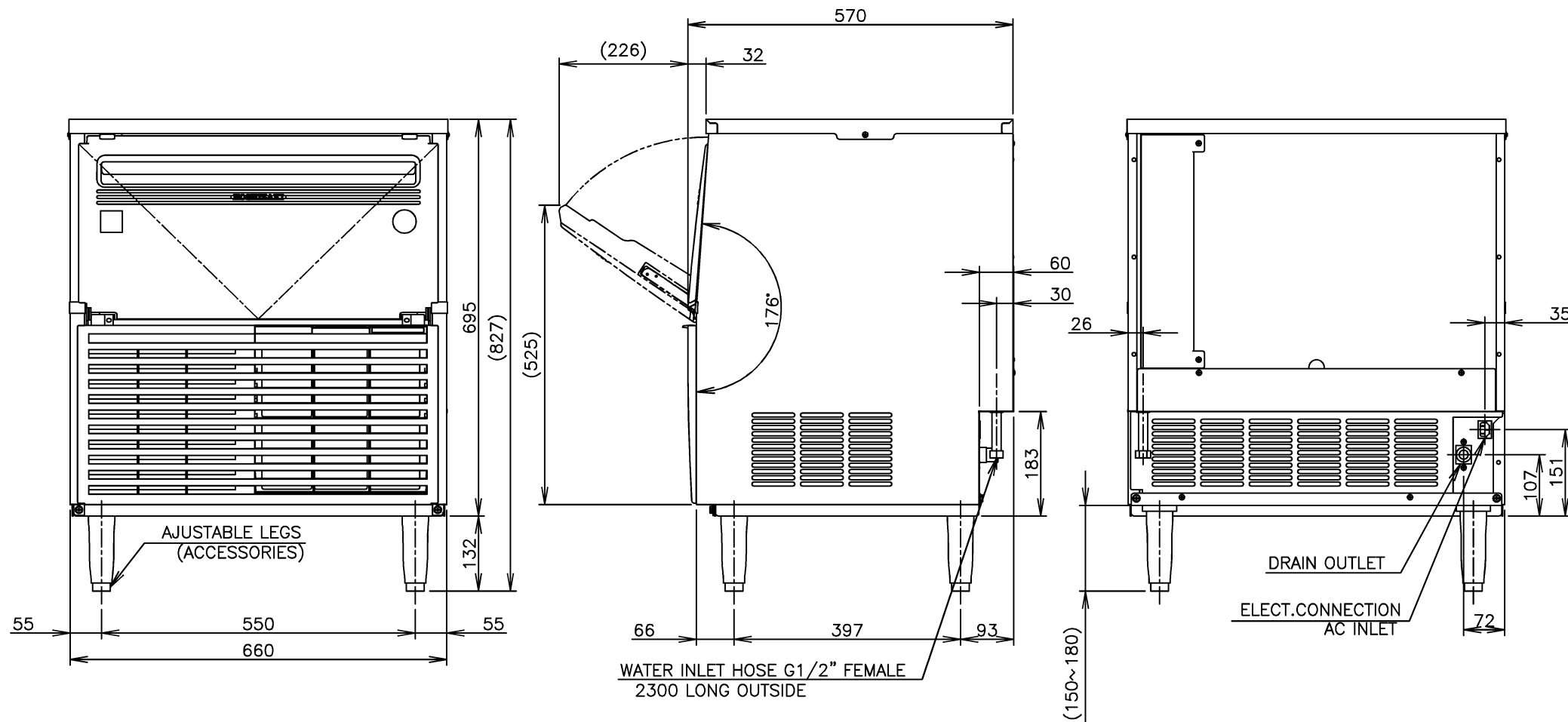
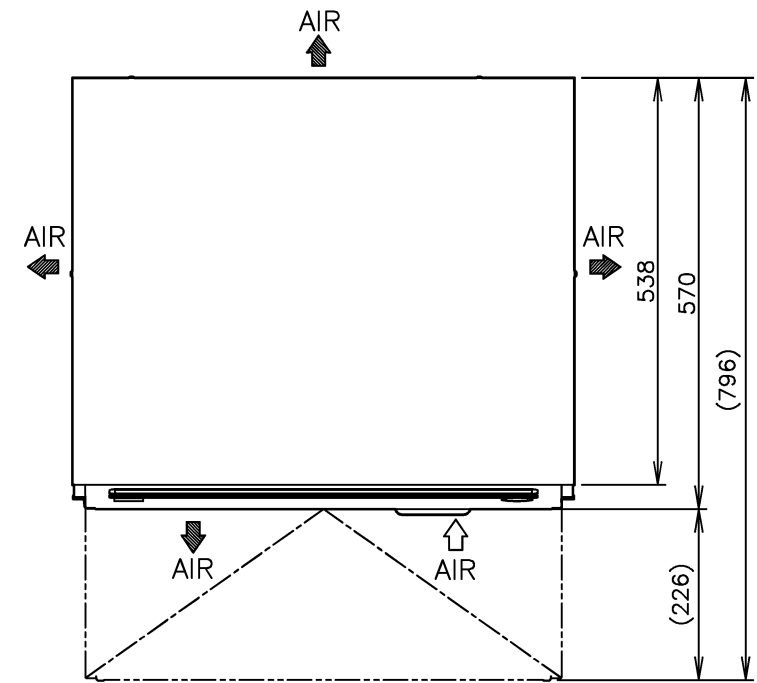

ITEM	Hoshizaki Cube Ice Maker	
MODEL	IM-45CA-25	
AC SUPPLY VOLTAGE	1 PHASE 220-240V 50Hz	
AMPERAGE	2.0A (AT.32°C, WT.21°C)	
STARTING AMPERAGE	16A	
ELECTRIC CONSUMPTION	310W (AT.32°C, WT.21°C)	
POWER FACTOR	63%	
POWER SUPPLY CAPACITY	Min. 1.05kVA (4.4A)	
ICE PRODUCTION PER 24h	Approx. 41kg (5mm) / 48kg (15mm) (AT.10°C, WT.10°C) Approx. 40kg (5mm) / 45kg (15mm) (AT.21°C, WT.15°C) Approx. 38kg (5mm) / 41kg (15mm) (AT.32°C, WT.21°C)	
WATER CONSUMPTION PER 24h	Approx. 0.19m ³ (5mm)(AT.10°C, WT.10°C) Approx. 0.13m ³ (5mm) (AT.21°C, WT.15°C) Approx. 0.11m ³ (5mm) (AT.32°C, WT.21°C)	
SHAPE OF ICE	Cube Approx. 25×25×23mm	
FREEZE CYCLE TIME	20min (5mm) (AT.21°C, WT.15°C)	
ICE PRODUCTION PER CYCLE	0.55kg/42pcs.(5mm) (AT.21°C, WT.15°C)	
MAX STORAGE CAPACITY	15kg(Bin Control Setting Approx. 8kg)	
DIMENSIONS	660mm(W) x 570mm(D) x 695mm(H)	
EXTERIOR	Stainless Steel, Plastic Door & Louver, Galvanized Steel(Rear)	
INSULATION	Polyurethane Foam	
INSULATION FOAM BLOWING AGENT	Cyclopentane / CFC Free / ODP: 0 / GWP: 3	
CONNECTIONS-ELECTRIC	X-Type Connection	
CONNECTIONS-WATER SUPPLY	Inlet G1/2" (connected at rear side)	
CONNECTIONS-DRAIN	Outlet I.D. φ22mm (connected at rear side)	
ICE MAKING SYSTEM	Cell type	
HARVESTING SYSTEM	Hot Gas Defrost	
COMPRESSOR	Hermetic	
CONDENSER	Air-cooled	
HEAT REJECTION	670W 576kcal/h	
EVAPORATOR	Tin-plated Copper Tube on Sheet and Cells	
REFRIGERANT CONTROL	Capillary Tube	
REFRIGERANT CHARGE	R134a / 160g	
ICE MAKING CONTROL SYSTEM	Thermistor, Timer	Controller Board
HARVESTING CONTROL SYSTEM	Thermistor	
BIN CONTROL SYSTEM	Microswitch with Time Delay	
ICE MAKING WATER CONTROL SYSTEM	Timer, Water Pan's movement	
ELECTRICAL PROTECTION	Class I Appliance, 5A Fuse	
COMPRESSOR PROTECTION	Auto-reset Overload Protector	
ICE MAKER PROTECTION	Interlock by Controller Board	
WEIGHT	Net weight 52kg/Gross weight 65kg	
PACKAGE	Carton 760mm(W) x 680mm(D) x 870mm(H)	
ACCESSORIES	Scoop, Leg, Installation Kit	
OPERATING CONDITIONS	Ambient Temp.:1-40°C, Water Supply Temp.:5-35°C Water Supply Pressure:0.07-0.78MPa(0.7-8bar) Voltage Range: Rated Voltage±6%	

* We reserve the right to make changes in specifications and design without prior notice.

HOSHIZAKI CUBE ICE MAKER IM-45CA-25

APPROVED KUROYANAGI	CHECKED MORIMOTO	DESIGNED KONDO	DRAWN WATANABE	SCALE 1/10	TRIGONOMETRY
YAMAGUCHI	ZHANG	2019.07.20	DATE	2014.03.24	DRAWING NO. D14207
APPROVED	DESIGNED	SYMBOL	DATE		SYMBOL