



---

STACKABLE CRESCENT CUBER

**KM-590DJ**  
**KM-590DWJ**  
**KM-590DJ-S**  
**KM-590DWJ-S**

# INSTRUCTION MANUAL

---

**HOSHIZAKI (SUZHOU) CO., LTD.**

No. 15 Qingqiu Street, Suzhou Industrial Park, Suzhou 215126 China

L1F137104 (051221)

***IMPORTANT***

This manual should be read carefully before the appliance is installed and operated. Read the warnings and guidelines contained in this manual carefully as they provide essential information for the continued safe use and maintenance of the appliance. Retain this manual for any further reference that may be necessary.

**CONTENTS**

Important Safety Information ..... 1

I. Specifications ..... 3

    A. Electrical and Refrigerant Data ..... 3

    B. Dimensions/Connections ..... 4

II. Installation and Startup Instructions ..... 7

    A. Checks Before Installation ..... 7

    B. How to Remove Panels ..... 7

    C. Location ..... 7

    D. Setup ..... 8

    E. Installation of Upper Unit ..... 9

    F. Electrical Connection ..... 10

    G. Installation of Remote Condenser Unit ..... 11

    H. Water Supply and Drain Connections ..... 15

    I. Final Checklist ..... 18

    J. Startup ..... 19

III. Cleaning and Maintenance Instructions ..... 19

    A. Cleaning and Sanitizing Instructions ..... 19

    B. Maintenance ..... 20

    C. Preparing the Icemaker for Long Storage ..... 21

IV. Warranty ..... 21

V. Disposal ..... 21

## Important Safety Information

Throughout this manual, notices appear to bring your attention to situations which could result in death, serious injury, damage to the appliance, or damage to property.

**⚠ WARNING** Indicates a hazardous situation which could result in death or serious injury.

**NOTICE** Indicates a situation which could result in damage to the appliance or property.

**IMPORTANT** Indicates important information about the installation, use, and care of the appliance.

### ⚠ WARNING

The appliance should be destined only to the use for which it has been expressly conceived. Any other use should be considered improper and therefore dangerous. The manufacturer cannot be held responsible for injury or damage resulting from improper, incorrect, and unreasonable use. Failure to install, operate, and maintain the appliance in accordance with this manual will adversely affect safety, performance, component life, and warranty coverage and may result in costly water damage.

**To reduce the risk of death, electric shock, serious injury, or fire, follow basic precautions including the following:**

- Only qualified service technicians should install and service the appliance.
- The appliance must be installed in accordance with applicable national, state, and local codes and regulations.
- Electrical connection must be hard-wired and must meet national, state, and local electrical code requirements. Failure to meet these code requirements could result in death, electric shock, serious injury, fire, or damage.
- The icemaker requires an independent power supply of proper capacity. See the specifications in this manual. Failure to use an independent power supply of proper capacity can result in a tripped breaker, blown fuse, damage to existing wiring, or component failure. This could lead to heat generation or fire.
- **THE ICEMAKER MUST BE GROUNDED.** Failure to properly ground the icemaker could result in death or serious injury.
- To reduce the risk of electric shock, do not touch the control switch with damp hands.
- Move the control switch to the "OFF" position and turn off the power supply before servicing. Lockout/Tagout to prevent the power supply from being turned back on inadvertently.
- Do not make any alterations to the appliance. Alterations could result in electric shock, serious injury, fire, or damage.
- The appliance is not intended for use by persons (including children) with reduced physical, sensory, or mental capabilities, or lack of experience and knowledge, unless they have been given supervision or instruction concerning use of the appliance by a person responsible for their safety.

## **⚠ WARNING, continued**

- Children should be properly supervised around the appliance.
- Do not climb, stand, or hang on the appliance or allow children or animals to do so. Serious injury could occur or the appliance could be damaged.
- Do not use combustible spray or place volatile or flammable substances near the appliance. They might catch fire.
- Keep the area around the appliance clean. Dirt, dust, or insects in the appliance could cause harm to individuals or damage to the appliance.

### **Additional Warning for Remote Models**

- **THE REMOTE CONDENSER UNIT MUST BE GROUNDED.** The power supply and ground connection to the remote condenser unit are supplied from the icemaker. Failure to properly ground the remote condenser unit could result in death or serious injury.
- Wire routing (conduit) and disconnect (if required) must meet national, state, and local electrical code requirements. Failure to meet these code requirements could result in death, electric shock, serious injury, fire, or damage.

## ***NOTICE***

- Follow the water supply, drain connection, and maintenance instructions carefully to reduce the risk of costly water damage.
- In areas where water damage is a concern, install in a contained area with a floor drain.
- Install the icemaker in a location that stays above freezing. Normal operating ambient temperature must be within 7°C to 38°C.
- Do not leave the icemaker on during extended periods of non-use, extended absences, or in sub-freezing temperatures. To properly prepare the icemaker for these occasions, follow the instructions in "IV. Preparing the Icemaker for Periods of Non-Use."
- Do not place objects on top of the appliance.
- The dispenser unit/ice storage bin is for ice use only. Do not store anything else in the dispenser unit/ice storage bin.

## I. Specifications

### A. Electrical and Refrigerant Data

The nameplate provides electrical and refrigerant data. The nameplate is located on the left panel. For certification marks, see the nameplate.

We reserve the right to make changes in specifications and design without prior notice.

#### 1. KM-590D\_J/KM-590D\_J-S

|                                  |   |   |
|----------------------------------|---|---|
| Model                            | KM-590DJ/<br>KM-590DJ-S   | KM-590DWJ/<br>KM-590DWJ-S   |
| Type                             | Air-cooled,<br>crescent cube ice  | Water-cooled,<br>crescent cube ice  |
| Power Supply                     | 1 phase 220-240V<br>50Hz/<br>1 phase 220-230V<br>60Hz   | 1 phase 220-240V<br>50Hz/<br>1 phase 220-230V<br>60Hz   |
| Power Supply<br>Capacity         | 3.64kVA (15.8A) /<br>3.83kVA (16.6A)  | 3.45kVA (15.0A) /<br>3.51kVA (15.3A)  |
| Electric<br>Consumption          | 2080W / 2310W<br>(AT:32°C, WT:21°C)   | 1741W / 1782W<br>(AT:32°C, WT:21°C)   |
| Ice Production<br>per 24h        | 630kg / 675kg<br>(AT:10°C, WT:10°C)   | 650kg / 645kg<br>(AT:10°C, WT:10°C)   |
| Dimensions                       | 1219mm(W) x<br>695mm(D) x<br>695mm(H)   | 1219mm(W) x<br>695mm(D) x<br>695mm(H)   |
| Refrigerant                      | R404A<br>1.90kg (GWP:3920,<br>CO <sub>2</sub> : 7.448t) /<br>1.80kg (GWP:3920,<br>CO <sub>2</sub> : 7.056t) | R404A<br>1.00kg (GWP:3920,<br>CO <sub>2</sub> : 3.920t) /<br>1.00kg (GWP:3920,<br>CO <sub>2</sub> : 3.920t) |
| Insulation Foam<br>Blowing Agent | Cyclopentane  | Cyclopentane  |
| Weight                           | Net:136kg<br>(Gross:154kg)  | Net:125kg<br>(Gross:143kg)  |
| Ambient Temp                     | 7 - 38°C  | 7 - 38°C  |
| Water Supply<br>Temp             | 7 - 32°C  | 7 - 32°C  |
| Water Supply<br>Pressure         | 0.07 - 0.8MPa<br>(0.7 - 8bar)   | 0.07 - 0.8MPa<br>(0.7 - 8bar)   |
| Voltage Range                    | 198 - 254V  | 198 - 254V  |

## B. Dimensions/Connections

### 1. KM-590DJ/KM-590DJ-S

Units: mm

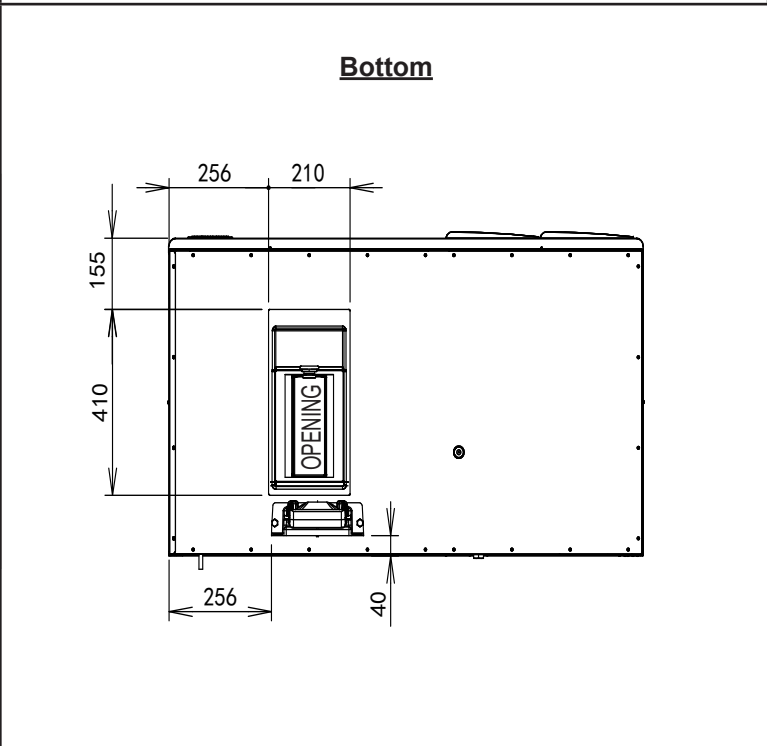
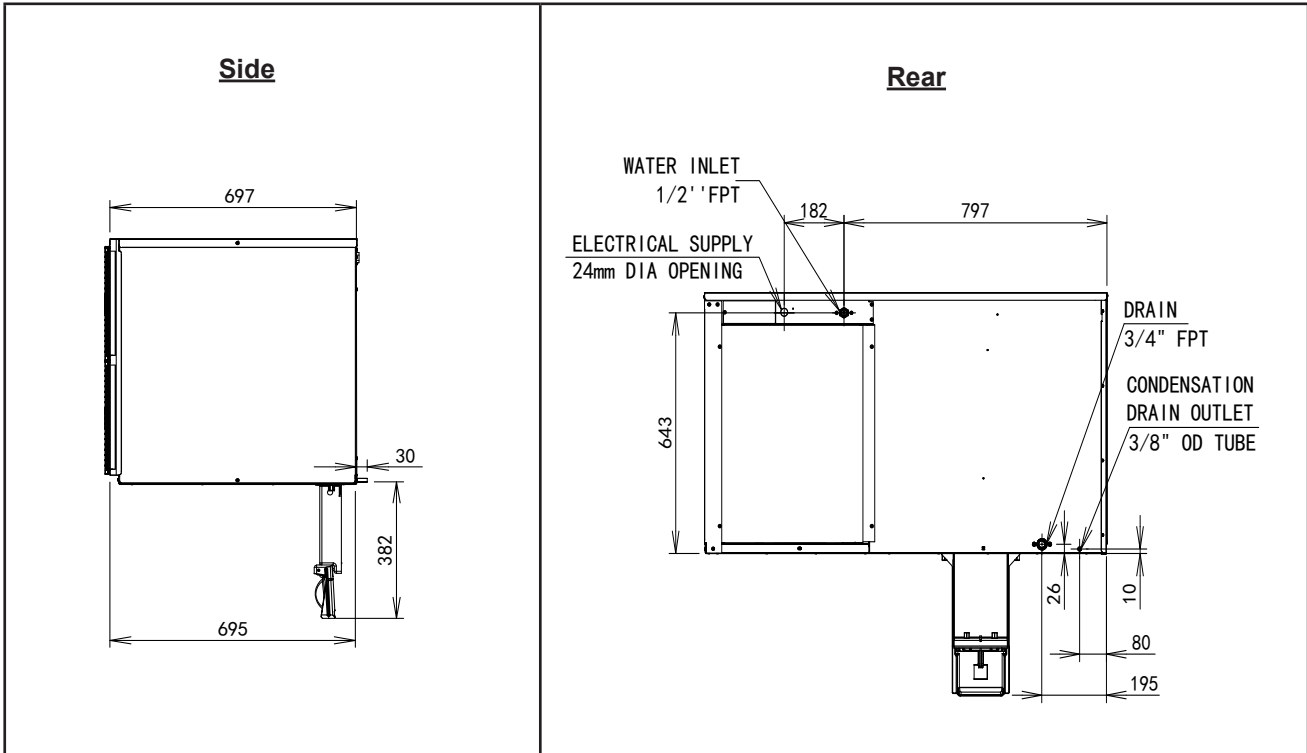

### NOTICE

- KM-590DJ/KM-590DJ-S: Allow 15 cm clearance at rear, sides, and top for proper air circulation and ease of maintenance and/or service should they be required.
- The ice storage bin opening must match the bottom opening as in the illustration.

2. KM-590DWJ/KM-590DWJ-S

Units: mm

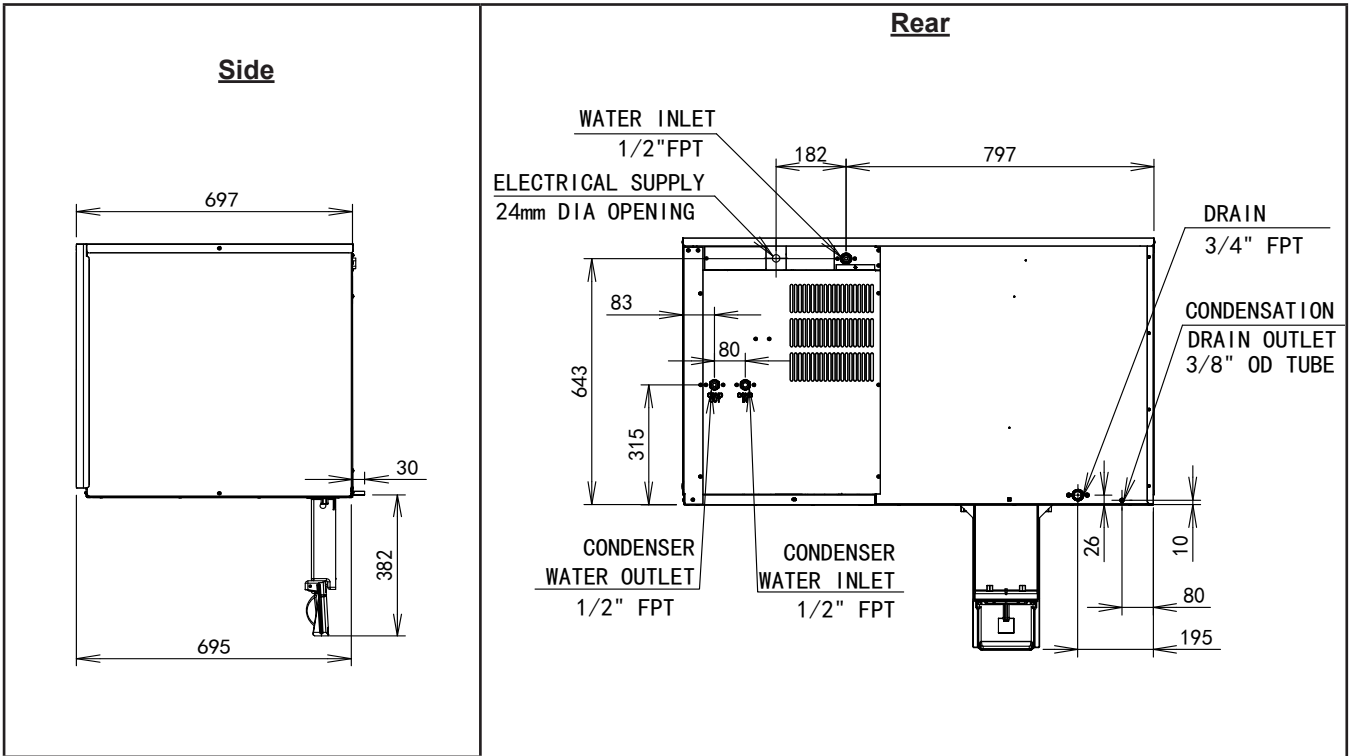

**NOTICE**

- KM-590DWJ/KM-590DWJ-S: Allow 15 cm clearance at rear, sides, and top for proper air circulation and ease of maintenance and/or service should they be required.
- The ice storage bin opening must match the bottom opening as in the illustration.

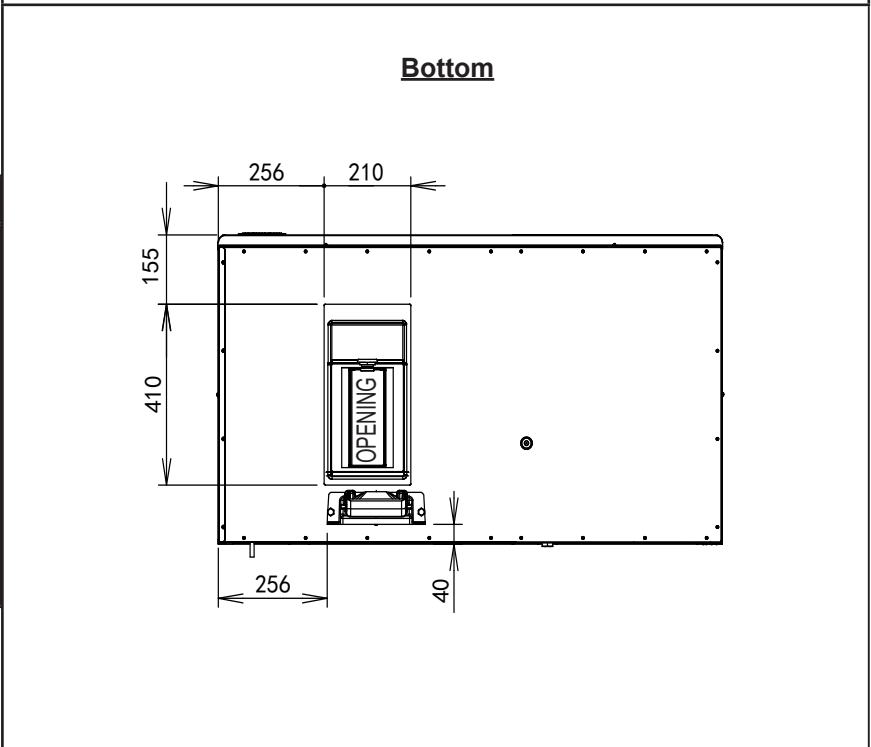

**Intentionally Left Blank**



## II. Installation and Startup Instructions

### ⚠ WARNING

1. This icemaker must be installed in accordance with applicable national, state, and local regulations.
2. **CHOKING HAZARD:** Ensure all components, fasteners, and thumbscrews are securely in place after installation. Make sure that none have fallen into the storage bin.

### A. Checks Before Installation

- Visually inspect the exterior of the shipping container and immediately report any damage to the carrier. Upon opening the container, any concealed damage should also be immediately reported to the carrier.
- Remove the shipping carton, tape, and packing material. If any are left in the icemaker, it will not work properly.  
**WARNING! Keep packing material (plastic bags and expanded polystyrene) away from children.**
- Remove the panels to prevent damage when installing the icemaker. See "II.B. How to Remove Panels."
- Remove the package containing the accessories.
  - Remove the protective plastic film from the panels. If the icemaker is exposed to the sun or to heat, remove the film after the icemaker cools.
- Check that the refrigerant lines do not rub or touch lines or other surfaces.
- Check that the compressor is snug on all mounting pads.
- See the nameplate on the side panel, and check that your voltage supplied corresponds with the voltage specified on the nameplate.
- This icemaker can be installed on a storage bin 48" wide or wider. For options, contact your local Hoshizaki distributor.
- On remote air-cooled model, a remote condenser unit is needed. Hoshizaki Remote Condenser Unit, Model URC-14FE is recommended.

### B. How to Remove Panels

See Fig. 1

- Front Panel: Remove the 2 screws. Lift up and towards you.
- Top Panel: Remove the 2 screws, then lift off.
- Side Panel (R): Remove the screw. Slide forward slightly and lift off.
- Insulation Panel: Remove the thumbscrew. Lift up slightly and pull towards you.
- Top Insulation: Lift off.

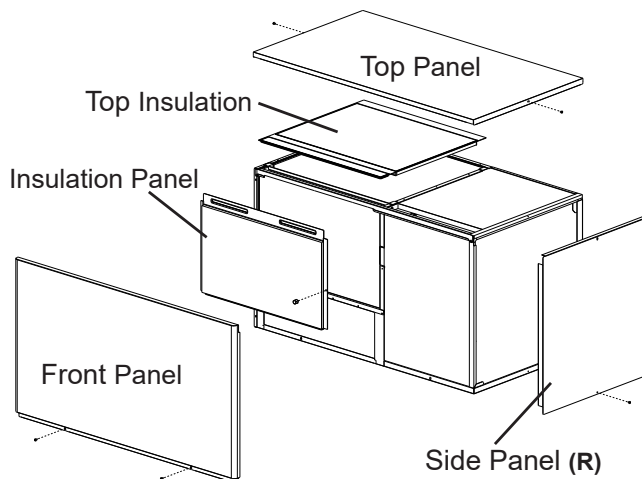

Fig. 1

### C. Location

#### CAUTION

1. This icemaker is not intended for outdoor use. Normal operating ambient temperature should be within 7°C to 38°C; Normal operating water temperature should be within 7°C to 32°C.  
Operation of the icemaker, for extended periods, outside of these normal temperature ranges may affect icemaker performance.
2. This icemaker will not work at sub-freezing temperatures. To prevent damage to the water supply line, drain the icemaker if the air temperature is going to go below 0°C. For details, see "III.C. Preparing the Icemaker for Long Storage."

For best operating results:

- The icemaker should not be located next to ovens, grills, or other high heat producing equipment.
- The location should provide a firm and level foundation for the equipment.
- Allow 15 cm clearance at rear, sides, and top for proper air circulation and ease of maintenance and/or service should they be required.

## D. Setup

### CAUTION

Before operating the icemaker, the bin control assembly must be installed correctly. Failure to properly install the assembly could result in ice backup and unit damage.

- 1) Follow the storage bin's setup procedure.
- 2) Position the storage bin in the selected permanent location.
- 3) Place the icemaker on top of the storage bin.
- 4) Secure the icemaker to the storage bin using the 2 mounting brackets and the bolts provided. See Fig. 2

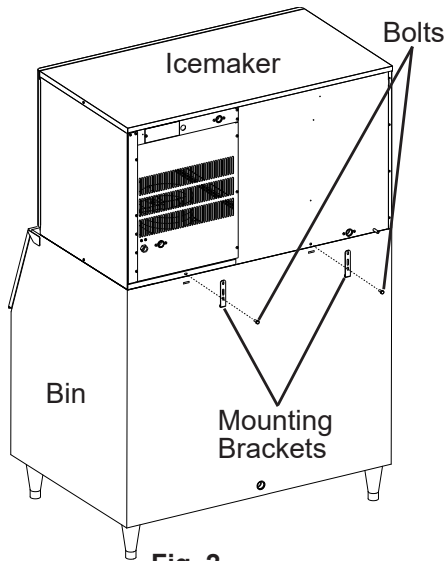

Fig. 2

- 5) Install the bin control assembly as follows:
  - a. Remove the baffle from the storage bin.
  - b. Remove the thumbscrew and bin control assembly from inside the icemaker. See Fig. 3.

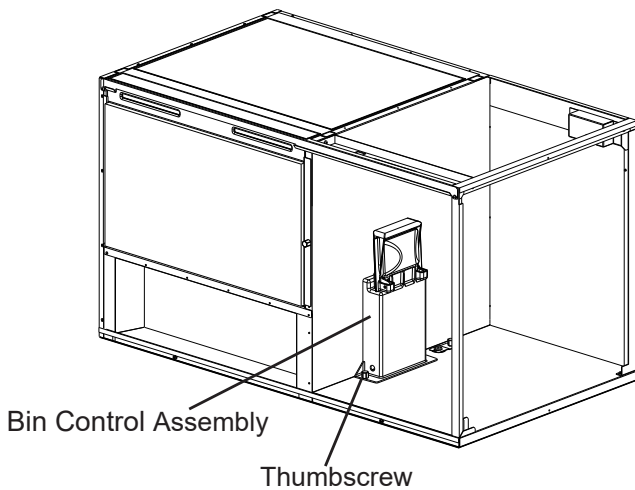

Fig. 3

- c. Use the thumbscrew removed in the previous step and the thumbscrew included in the accessory bag to secure the bin control assembly to the bottom of the icemaker. See Fig. 4.
- d. Remove the bin control cable bracket from inside the icemaker, then route the bin control cable through the hole in the bin control bracket and the hole in the bottom of the icemaker. Route the cable through the bushing in the bin control cable bracket, then secure the bracket. Leave as little slack as possible inside the storage bin. Route the cable through the wire saddles.
- e. Connect the bin control cable connector to wire harness connector A coming from the control box.
 

Note:

  1. Wire harness has one connector to plug into the bin control cable and another connector for use if an upper unit is installed.
  2. Wire harness is connected to the control board red K4 connector.
- f. Make sure the bin control cable and wire harness are secured in the wire saddles and do not interfere with any components.

### Connection Overview

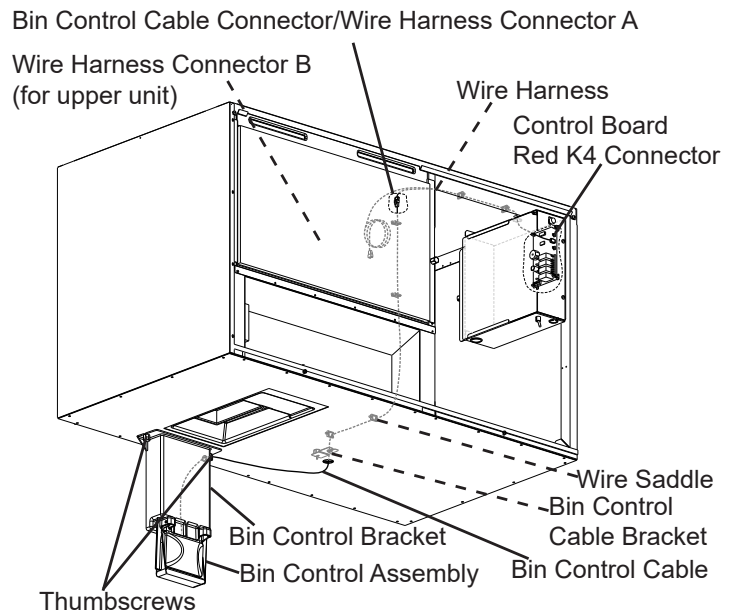

### Connection Detail

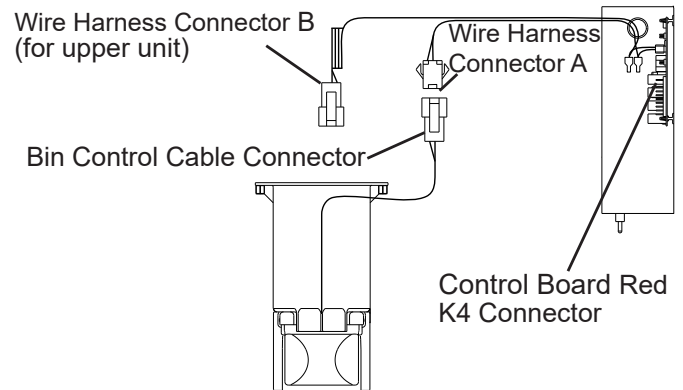
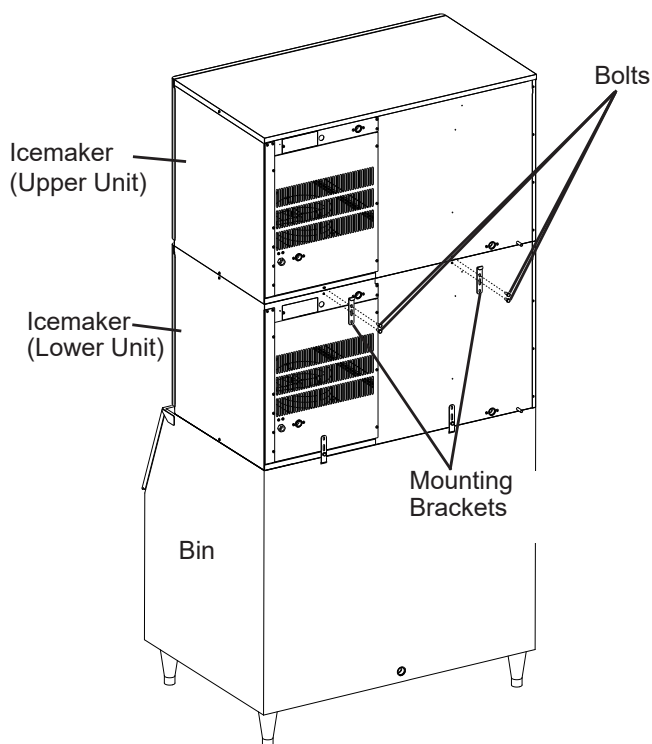

Fig. 4

- 6) Level the icemaker and storage bin in both the left-to-right and front-to-rear directions. Adjust the storage bin legs to make the icemaker level.
- 7) Replace the panels and storage bin baffle in their correct positions unless you are installing an upper unit. If installing an upper unit, see "II.E. Installation of Upper Unit."

**E. Installation of Upper Unit**

- 1) See "II.D. Setup" for the lower unit installation.
- 2) Remove the top panel and the top insulation of the lower unit. The top panel and the top insulation of the lower unit are not required when installing an upper unit.
- 3) Unpack the upper unit and remove the shipping carton, tape, and packing material.
- 4) Remove the panels of the upper unit.
- 5) Stack the upper unit on top of the lower unit.
- 6) Secure the upper unit to the lower unit using the 2 mounting brackets and the bolts provided. See Fig. 5.



**Fig. 5**

- 7) Remove the bin control cable bracket from inside the upper unit. See Fig. 6. Leave the upper unit's bin control assembly in its original position. It will not be used.
- 8) Route lower unit wire harness connector B through the hole in the bottom of the upper unit. Route the wiring through the bushing in the bin control cable bracket, then through the wire saddles.
- 9) Connect lower unit wire harness connector B to upper unit wire harness connector A.  
Note: Wire harness is connected to the control board red K4 connector.
- 10) Make sure the wire harnesses are secured in the wire saddles and do not interfere with any components.
- 11) Secure the bin control cable bracket.
- 12) Replace the panels and storage bin baffle in their correct positions.

**Upper Unit Connection Overview**

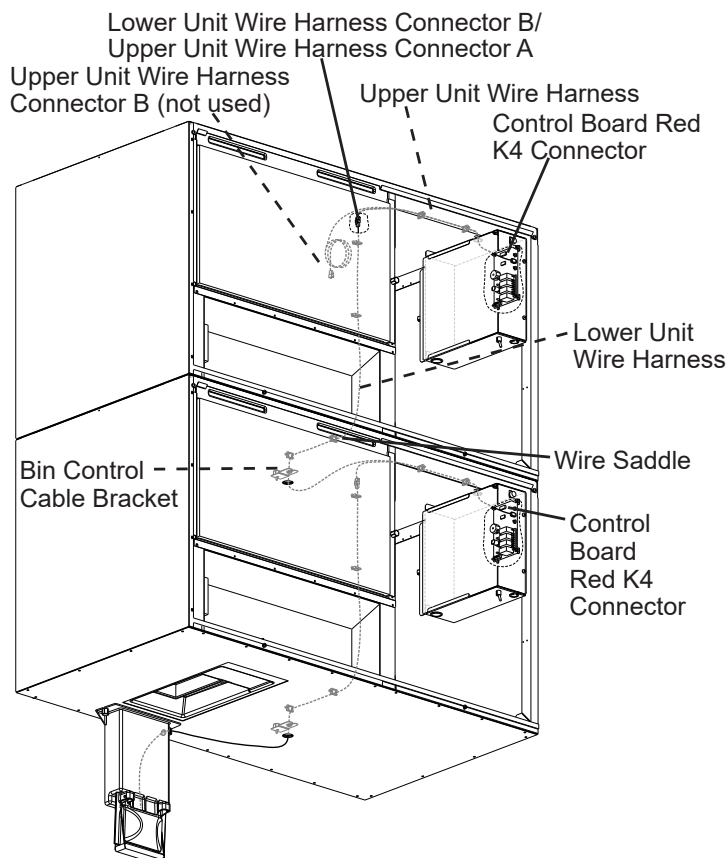

**Upper Unit Connection Detail**

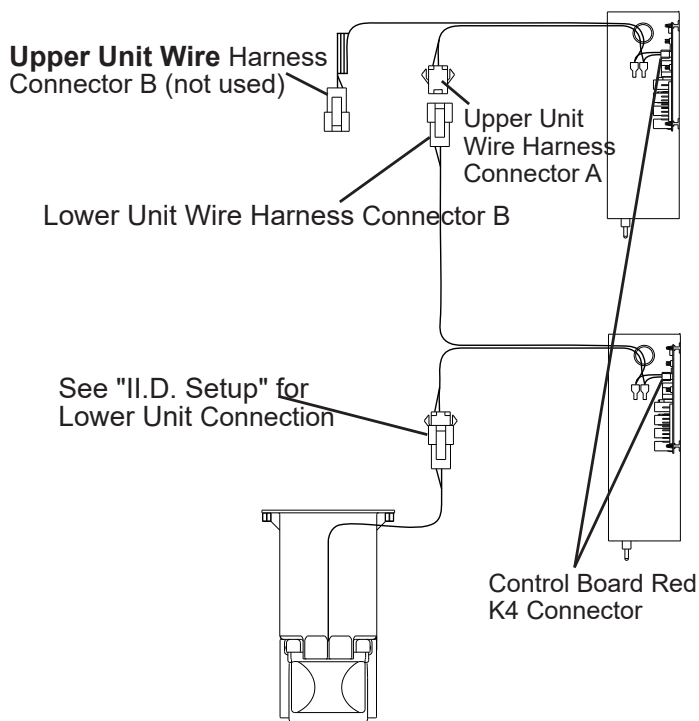

**Fig. 6**

## F. Electrical Connection

### ⚠ WARNING

#### For All Models

1. Hard-wired electrical connection is recommended. Electrical connection must meet national, state, and local electrical code requirements. Failure to meet these code requirements could result in death, electric shock, serious injury, fire, or severe damage to equipment.
2. This unit requires an independent power supply of proper capacity. See the nameplate for electrical specifications. Failure to use a properly sized breaker or fuse can result in a tripped breaker, blown fuses, or damage to existing wiring. This could lead to heat generation or fire.
3. **THIS UNIT MUST BE GROUNDED (EARTHED).** Failure to properly ground (earth) this unit could result in death or serious injury.

#### Additional Warnings for Remote Air-Cooled Model

4. **THE REMOTE CONDENSER UNIT MUST BE GROUNDED (EARTHED).** The power supply and ground (earth) wire to the remote condenser unit are supplied from the icemaker. See "II.G.6. Electrical Connection."
5. To reduce the risk of electric shock, make all remote condenser unit connections before connecting the icemaker power supply.
6. On remote air-cooled model, the icemaker should have power for a minimum of 4 hours prior to startup to prevent compressor damage.

- The opening for the power supply connection is 7/8" (22.2 mm) DIA to fit a 1/2" trade size conduit.
- If a power cord is used to provide electricity to the icemaker in place of a hard-wired (conduit) connection, a strain relief (gland) of the appropriate size for the power cord must be installed at the 7/8" (22.2 mm) diameter opening for the power supply connection.

**WARNING! The power cord and its conductors must be appropriately sized and rated for the electrical consumption of this icemaker. See the nameplate for electrical specifications.**

#### For the UK and the Republic of Ireland Only

For installations to pre-IEC 60446 field wiring, the colors of the wires in the icemaker's junction box may not correspond with the colors of the field wiring. In this case, proceed as follows:

The icemaker terminal with the green-and-yellow wire must be connected to the incoming green or green-and-yellow wire which connects to the terminal marked with the letter "E", the symbol  $\perp$ , or the color green or green-and-yellow. The icemaker terminal with the light blue wire must be connected to the incoming black wire which connects to the terminal marked with the letter "N" or the color black. The icemaker terminal with the brown wire must be connected to the incoming red wire which connects to the terminal marked with the letter "L" or the color red.

- Usually an electrical permit and services of a licensed electrician are required.
- The maximum allowable voltage variation is  $\pm 10$  percent of the nameplate rating.
- The neutral terminal on the terminal block (light blue wire) must be connected to the neutral conductor of the power source. See Fig. 7. **CAUTION! Miswiring may result in severe damage to the icemaker.**

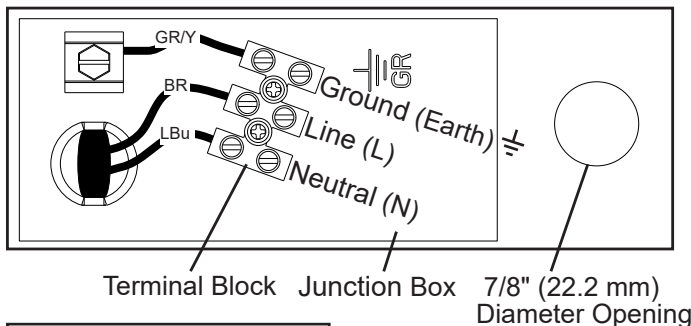

Wire Color Code:  
 GR/Y—green-and-yellow  
 BR—brown  
 LBU—light blue

Fig. 7

**G. Installation of Remote Condenser Unit**

| <b>⚠ WARNING</b>  |
|---|
| <ol style="list-style-type: none"> <li>1. Installation of remote condenser unit must be performed by properly trained and certified service personnel.</li> <li>2. Failure to install the equipment within these guidelines may adversely affect safety, performance, component life, and warranty coverage.</li> </ol> |

**1. Checks Before Installation**

- 1) Remove the shipping carton, tape, and packing material.
- 2) Check that the refrigerant lines do not rub or touch lines or other surfaces, and that the fan blades move freely.

**2. Location**

| <b>CAUTION</b>  |
|---|
| <ol style="list-style-type: none"> <li>1. The remote condenser unit is intended for outdoor use. Normal operating ambient temperature should be within -29°C to +50°C. Operation of the remote condenser unit, for extended periods, outside of this normal temperature range may affect icemaker performance.</li> <li>2. The maximum line length for the standard refrigerant charge is 20 m. With additional refrigerant, the maximum line length is 30.5 m. For details, see "II.G.5. Line Set Exceeding 20 m."</li> <li>3. The maximum vertical distance between the remote condenser unit and the icemaker is 10 m above or 3 m below the icemaker. These distances are measured fitting to fitting. See Fig. 8.</li> </ol> |

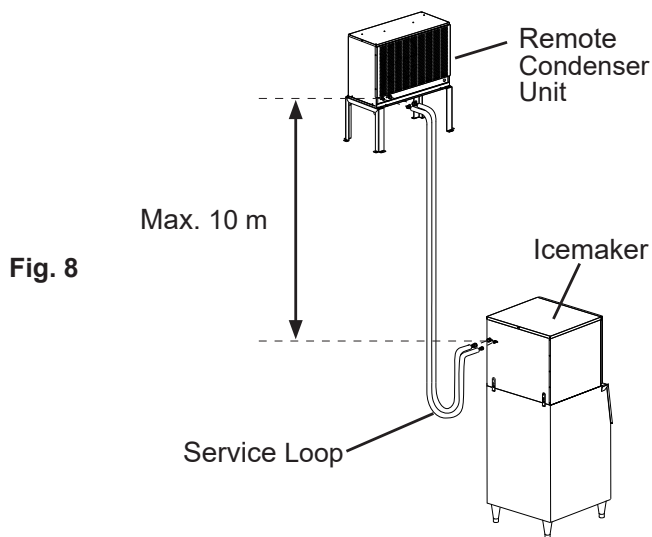

The remote condenser unit must be positioned in a permanent site under the following guidelines:

- A firm and flat site.
- A dry and well ventilated area with 61 cm clearance in both front and rear for proper air circulation and ease of maintenance and/or service should they be required. See Fig. 9.

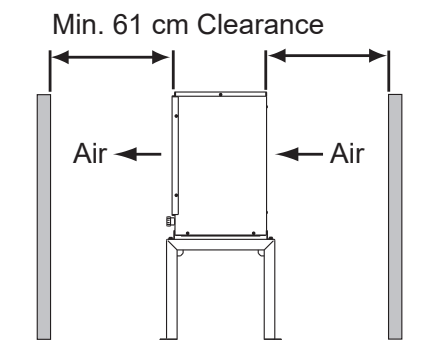

**Fig. 9**

**3. Setup**

- 1) Secure the legs to the remote condenser unit with the 8 bolts and nuts provided. See Fig. 10.
- 2) The legs have 8 mounting holes. Secure the legs to the permanent site with 8 bolts (not included).

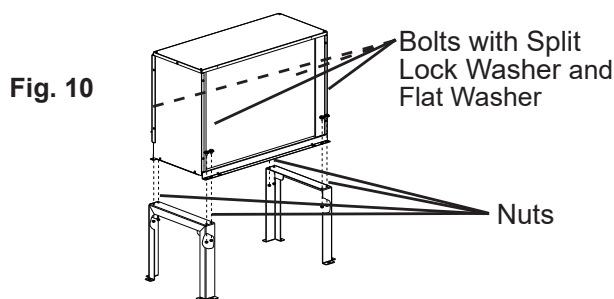

**Fig. 10**

**4. Line Set**

| <b>CAUTION</b>   |
|--|
| <ol style="list-style-type: none"> <li>1. The icemaker, line set, and remote condenser unit must contain the same type of refrigerant. Mixing of refrigerants will result in improper operation and possible damage to the refrigeration system.</li> <li>2. The maximum line length for the standard refrigerant charge is 20 m. With additional refrigerant, the maximum line length is 30.5 m. For details, see "II.G.5. Line Set Exceeding 20 m."</li> </ol> |

- 1) Route a 1/2" OD copper tube discharge line and a 3/8" OD copper tube liquid line between the remote condenser unit and the icemaker. Leave a service loop behind the icemaker to allow the icemaker to be pulled out for service. See Fig. 11.

| <b>CAUTION</b>   |
|--|
| <ol style="list-style-type: none"> <li>1. Ensure that there are no traps and no kinks in the line set.</li> <li>2. Do not coil extra line set. Fabricate the line set to the proper length.</li> </ol> |

- 2) Insulate the two copper tubes separately.
- 3) Install Parker quick connect couplings on each end. OS-QUICK, an optional Hoshizaki universal quick connect coupling kit, is recommended. **CAUTION! Before brazing, remove the Schrader valve core from the access port. When brazing, protect the coupling by using a wet cloth to prevent the coupling from overheating.**
- 4) Allow the coupling to cool, then replace the Schrader valve core.



- 5) Use an electronic leak detector or soap bubbles to check for leaks. Add a trace of refrigerant to the lines through the Schrader access ports on the Parker quick connect couplings (if using an electronic leak detector), and then raise the pressure using nitrogen gas (1.0MPa (10 bar)). **WARNING! DO NOT use R-404A as a mixture with pressurized air for leak testing.**
- 6) Evacuate through the Schrader access ports on the Parker quick connect couplings and charge with R-404A vapor to a pressure of 0.1-0.2MPa (1 to 2 bar).
- 7) Connect the refrigerant lines to the appropriate male fittings on the remote condenser unit first and then at the icemaker. Make a proper connection as follows:
  - a. Remove the protective covers from the male fitting and female coupling.
  - b. Apply Polyol Ester (POE) refrigerant oil or Parker Super O Lube to the entire male fitting, including O-ring, diaphragm, and threads, before making the connection. See Fig. 12.

At this point, the nut has covered most of the threads on the male fitting.

- e. Mark a reference line on the female coupling and the remote condenser unit or icemaker panel. Using a backup wrench on the back of the female coupling, tighten the six-sided nut of the female coupling an additional 1/6 turn. See Fig. 13.

- 8) If the line set exceeds 20 m, see "II.G.5 Line Set Exceeding 20 m" for proper charging of the unit.

## 5. Line Set Exceeding 20 m

### CAUTION

The icemaker, line set, and remote condenser unit must contain the same type of refrigerant. Mixing of refrigerants will result in improper operation and possible damage to the refrigeration system.

The maximum line length for the standard refrigerant charge is 20 m. Should an installation require a longer line length, additional refrigerant must be added. Add 40 g of R-404A for each meter over 20 m to a maximum of 30.5 m. Your nearest Hoshizaki Service office is available for recommendations.

After weighing in the additional charge, mark the unit's nameplate to show the new correct total refrigerant charge.

### CAUTION

Do not use thread sealant on the fittings. Use POE refrigerant oil or Parker Super O Lube only.

- c. Make sure the male fitting and female coupling are properly aligned, then start the connection by hand to ensure that it is not cross threaded.
- d. Tighten the connection with a wrench until it is tight.

Fig. 11

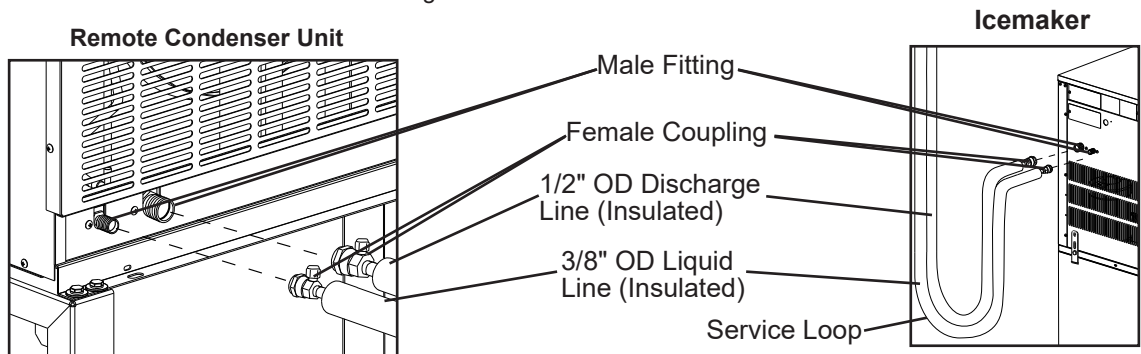

Fig. 12

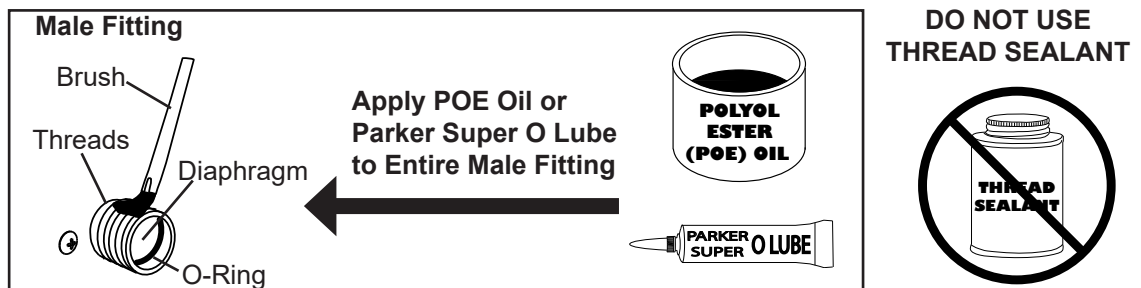
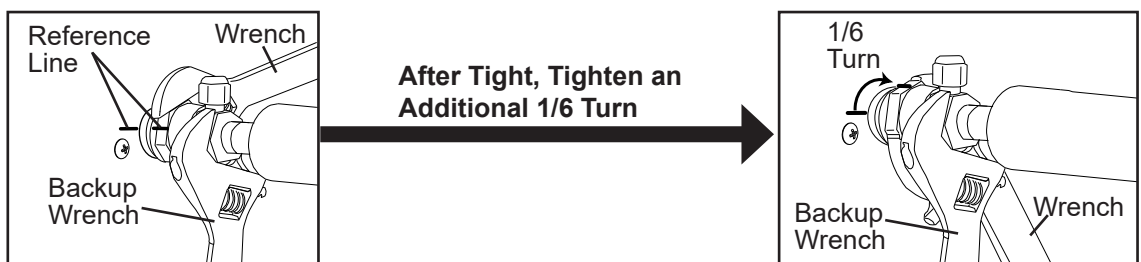

Fig. 13



6. Electrical Connection

**⚠ WARNING**

1. Electrical connection must meet national, state, and local electrical code requirements. Failure to meet these code requirements could result in death, electric shock, serious injury, fire, or severe damage to equipment.
2. **THE REMOTE CONDENSER UNIT MUST BE GROUNDED (EARTHED).** Install a proper ground (earth) wire from the icemaker's fan motor junction box terminal block to the remote condenser unit's terminal block. See Fig. 14. Use wire of an appropriate gage and outdoor rating. Failure to properly ground (earth) the unit could result in death or serious injury.
3. Install line and neutral wires from the icemaker's fan motor junction box terminal block to the remote condenser unit's terminal block. Use wire of an appropriate gage and outdoor rating.
4. If a power supply cord is used instead of conduit to connect the icemaker to the remote condenser unit, this cord should be rated for outdoor use. A certified strain relief (gland) rated IPX4 should be used where the cord enters the remote condenser unit.
5. Do not connect the remote condenser unit to an external power source.
6. To reduce the risk of electric shock, make all remote condenser unit connections before connecting the icemaker power supply.
7. On remote air-cooled models, the icemaker should have power for a minimum of 4 hours prior to startup to prevent compressor damage.

- Usually an electrical permit and services of a licensed electrician are required.
  - The opening for the power supply connection is 7/8" (22 mm) DIA to fit a 1/2" trade size conduit.
- 1) Remove the louver panel.
  - 2) Remove the icemaker's fan motor junction box cover. Remove the remote condenser unit's junction box cover.
  - 3) Install a ground (earth) wire from the icemaker's fan motor junction box terminal block to the remote condenser unit's terminal block. Use wire of an appropriate gage and outdoor rating.
  - 4) Install line and neutral wires from the icemaker's fan motor junction box terminal block to the remote condenser unit's terminal block. Use wire of an appropriate gage and outdoor rating. **WARNING! The remote condenser unit fan motors operate on 115VAC. DO NOT connect the remote condenser unit to the 230VAC mains power supply.**
  - 5) Replace the junction box covers and the louver panel in their correct positions.

Fig. 14

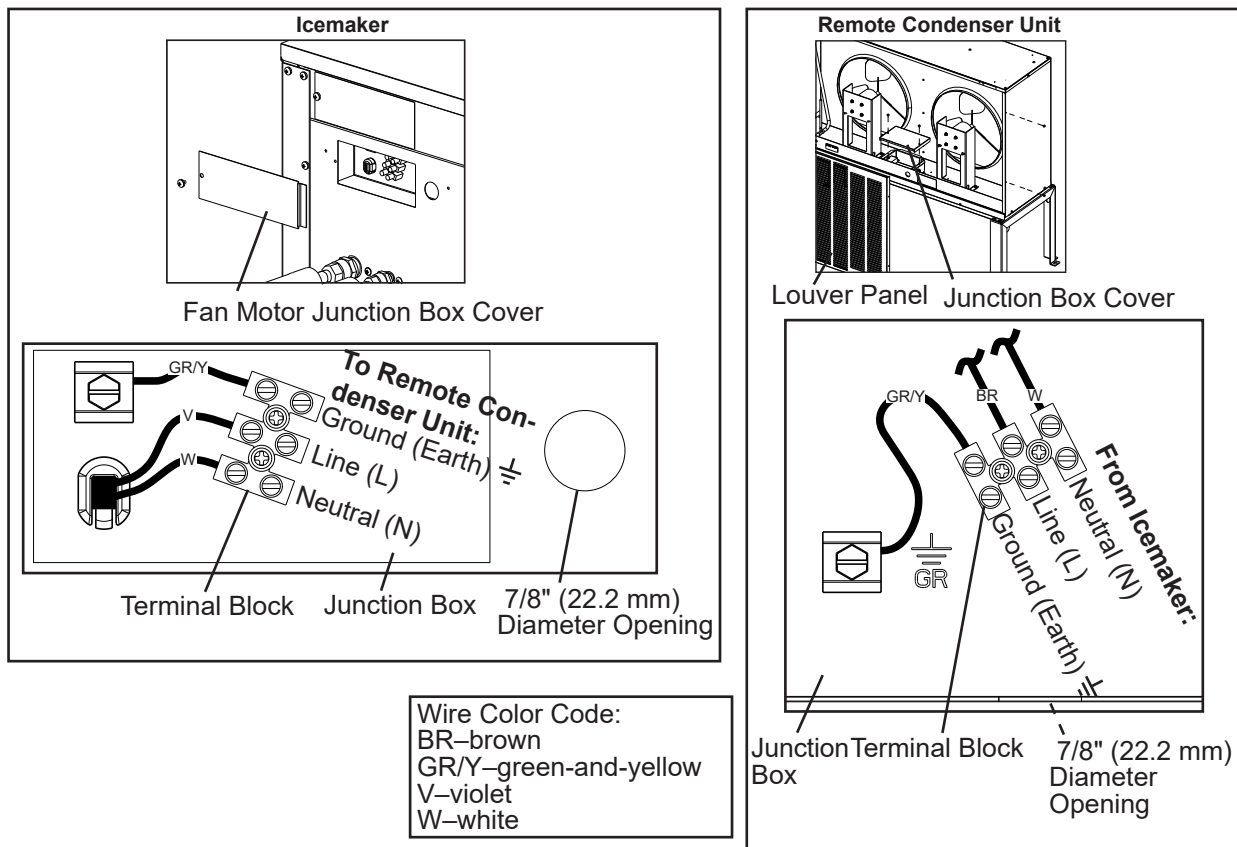

## 7. Stacking Remote Condenser Units

- 1) Install the lower remote condenser unit as described earlier in this section.
- 2) Place the upper remote condenser unit on top of the lower. See Fig. 15.
- 3) Secure the upper remote condenser unit to the lower remote condenser unit with the 4 screws provided.
- 4) Install refrigerant lines and make electrical connection as described earlier in this section.

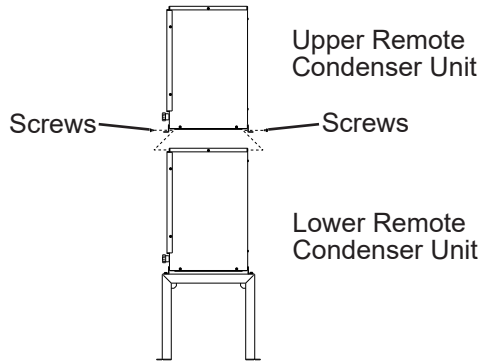

**Fig. 15**



**H. Water Supply and Drain Connections**

See Fig. 16, 17, or 18

**⚠ WARNING**

1. Water supply and drain connections must be installed in accordance with applicable national, state, and local regulations.
2. The icemaker water supply must be potable water.
3. Normal operating water temperature should be within 7°C to 32°C. Operation of the icemaker, for extended periods, outside of this normal temperature range may affect icemaker performance.
4. Water supply pressure should be a minimum of 0.07MPa (0.7 bar) and a maximum of 0.78MPa (7.8 bar). If the pressure exceeds 0.78MPa (7.8 bar), the use of a pressure reducing valve is required. DO NOT throttle back the supply tap.
5. To prevent damage to equipment, do not operate the icemaker when the water supply is off, or if the pressure is below 0.07MPa (0.7 bar). Do not run the icemaker until the proper water pressure is reached.
6. This icemaker will not work at sub-freezing temperatures. To prevent damage to the water supply line, drain the icemaker if the air temperature is going to go below 0°C. For details, see "III.C. Preparing the Icemaker for Long Storage."

• A plumbing permit and services of a licensed plumber may be required in some areas.

- External filters, strainers, or softeners may be required depending on water quality. Contact your local Hoshizaki distributor for recommendations.
- The icemaker and condensation drain line(s), storage bin drain line, and water-cooled condenser drain line (if applicable) must be run separately. When stacking units, each unit must have independent drain lines.
- Drain lines must have 2cm tall per 1 m on horizontal runs to get a good flow. A vented tee connection is also required for proper flow.
- Drain lines should not be piped directly to the sewer system. An air gap of a minimum of 5 vertical centimeter should be between the end of the drain pipes from the icemaker and condensation drain, storage bin, and water-cooled condenser (if applicable) and the floor drain.

**1. Icemaker**

- Icemaker water supply inlet is 1/2" female pipe thread (FPT). A minimum of 3/8" (10 mm) nominal copper water tubing is recommended for the icemaker water supply line.
- An icemaker water supply line shut-off valve and drain valve should be installed. A ball valve is recommended for the shut-off valve. If another type of valve is used, it should not have an opening smaller than the water supply line ID as this can cause a reduced water flow rate which can lead to poor harvest performance and/or freeze up.
- Icemaker drain outlet is 3/4" FPT. A minimum of 3/4" (18 mm) nominal hard pipe is recommended for the icemaker drain line. Condensation drain outlet is 3/8" (9.5 mm) OD hard tube. The condensation drain line can be connected to the icemaker drain line or can be run separately.

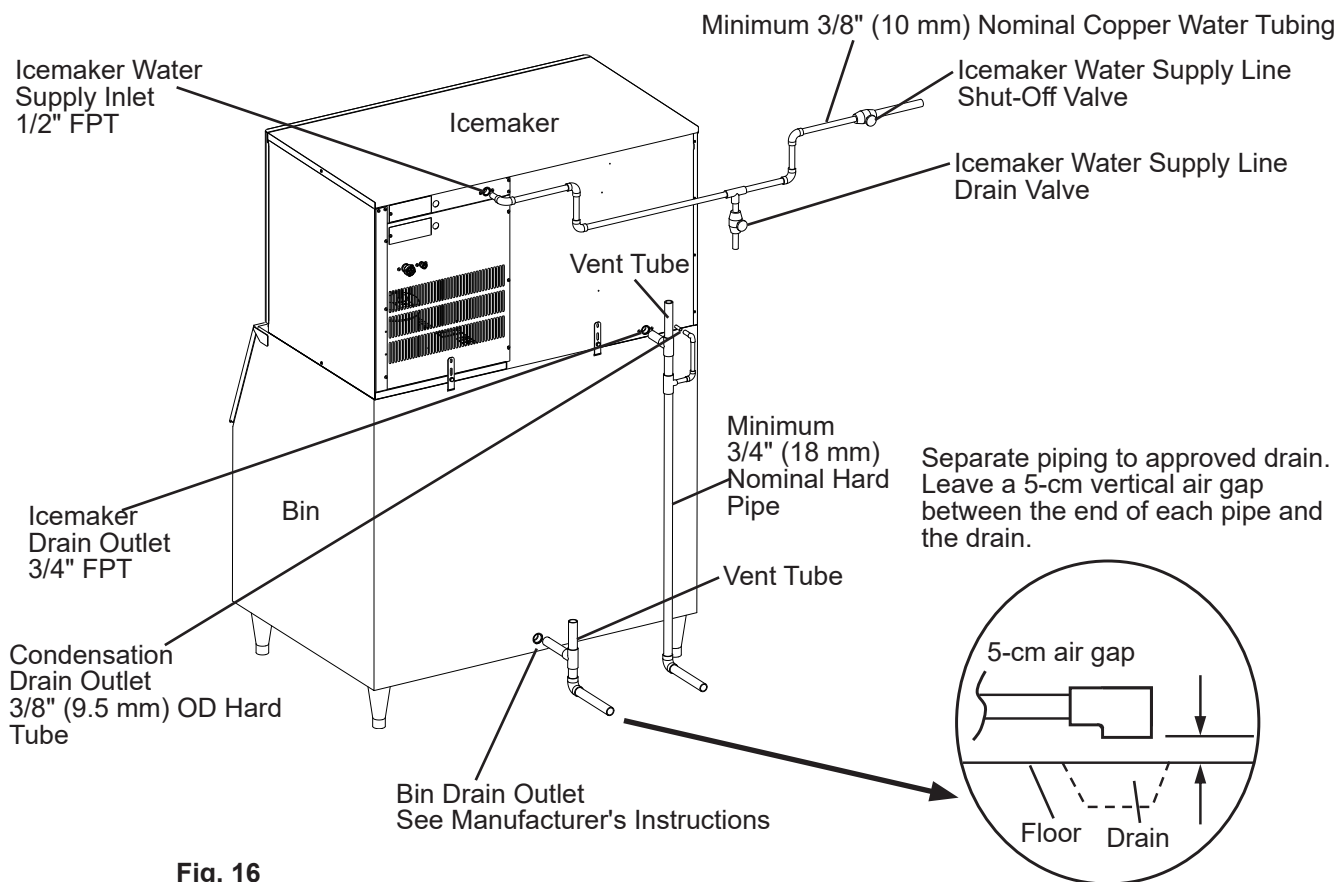

Fig. 16

**KM-590DJ/KM-590DJ-S  
KM-590DSJ**

## 2. Water-Cooled Condenser

### a) Connection to an Open Drain System

- Connecting potable water to the condenser will not affect performance but may result in high use/waste.
- Condenser water supply inlet is 1/2" female pipe thread (FPT). A minimum of 3/8" (10 mm) nominal copper water tubing is recommended for the condenser water supply line.
- A condenser water supply line shut-off valve and drain valve should be installed.
- Condenser drain outlet is 1/2" FPT. A minimum of 3/8" (10 mm) nominal hard pipe is recommended for the condenser drain line.
- In some areas, a back flow preventer may be required in the cooling water circuit.

- In order to maintain the proper high side pressure, the condenser water supply inlet temperature should not drop below 7°C and the condenser drain outlet temperature must be in the 40°C to 46°C range. Once the icemaker installation is complete, confirm the condenser drain outlet temperature 5 minutes after a freeze cycle starts. If the condenser drain outlet temperature is not in the proper range, use a flat blade screwdriver to rotate the adjustment screw on the water-regulating valve until the temperature is in the proper range (rotate counterclockwise to raise temperature or clockwise to lower temperature).

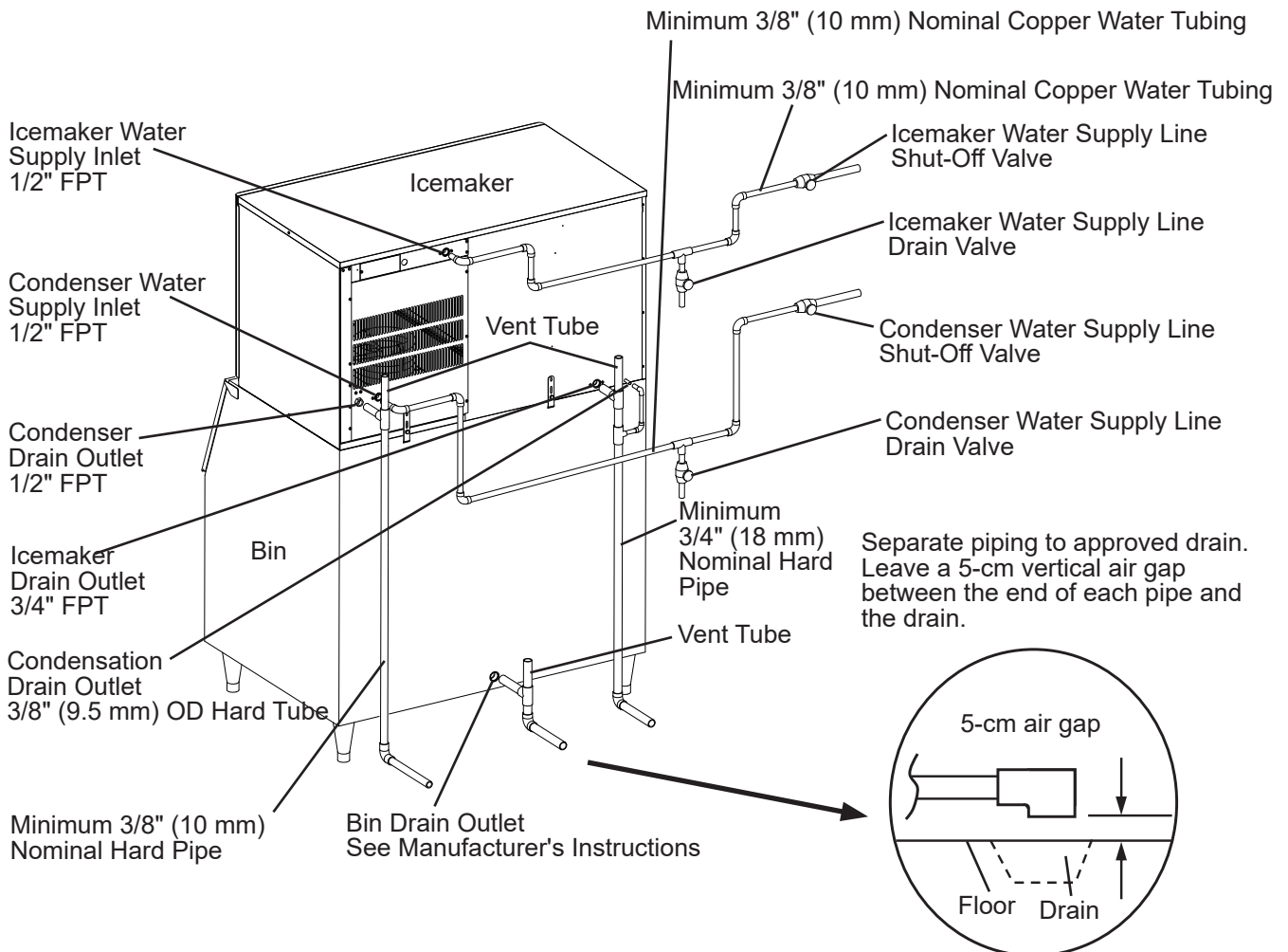

Fig. 17

**KM-590DWJ/KM-590DWJ-S**  
**Connection to an Open Drain System**

**b) Connection to a Closed Loop System**

- Condenser water supply inlet is 1/2" female pipe thread (FPT). A minimum of 3/8" (10 mm) nominal copper water tubing is recommended for the condenser water supply line.
- Condenser return outlet is 1/2" FPT. A minimum of 3/8" (10 mm) nominal copper water tubing is recommended for the condenser return line.
- Shut-off valves and drain valves should be installed at both the condenser water supply inlet and condenser return outlet.
- The water supply to the condenser should not drop below 15 LPM.
- The pressure differential between the condenser water supply inlet and condenser return outlet must be no less than 0.07MPa (0.7 bar).
- When using a glycol blend, the solution mixture should be less than 30% glycol.

- In order to maintain the proper high side pressure, the condenser water supply inlet temperature should not drop below 7°C and the condenser return outlet temperature must be in the 40°C to 46°C range. Once the icemaker installation is complete, confirm the condenser return outlet temperature 5 minutes after a freeze cycle starts. If the condenser return outlet temperature is not in the proper range, use a flat blade screwdriver to rotate the adjustment screw on the water-regulating valve until the temperature is in the proper range (rotate counterclockwise to raise temperature or clockwise to lower temperature).

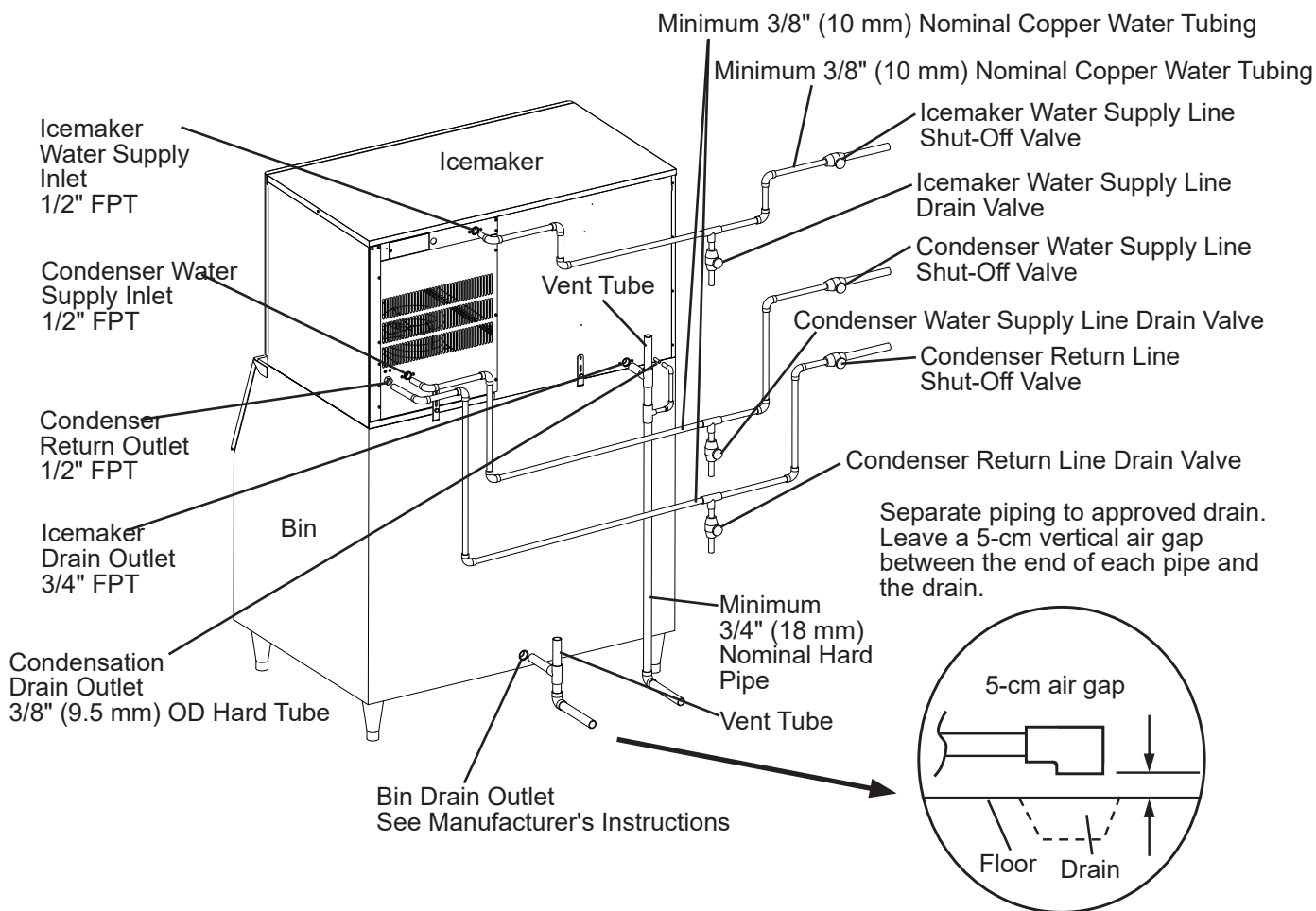

Fig. 18

**KM-590DWJ/KM-590DWJ-S**  
**Connection to a Closed Loop System**

## I. Final Checklist

**⚠ WARNING**

**CHOKING HAZARD:** Ensure all components, fasteners, and thumbscrews are securely in place after installation. Make sure that none have fallen into the storage bin.

- 1) Is the icemaker level?
- 2) Is the icemaker in a site where the ambient temperature is within 7°C to 38°C and the water temperature within 7°C to 32°C all year around?
- 3) Is there at least 15 cm clearance at sides, rear, and top of the icemaker for proper air circulation and ease of maintenance and service?
- 4) Have the shipping carton, tape, and packing material been removed from the icemaker? Are the cube guides in their correct positions? See Fig. 19. Are the separators between the evaporator banks properly attached to their holding clips?
- 5) Are all components, fasteners, and thumbscrews securely in place?
- 6) Have all electrical and water connections been made? Do electrical and water connections meet all national, state, and local code and regulation requirements?
- 7) Has the power supply voltage been checked or tested against the nameplate rating? Has a proper ground (earth) been installed to the icemaker? On remote air-cooled model, has a proper ground (earth) also been installed to the remote condenser unit?
- 8) Are the water supply line shut-off valves and drain valves installed? Has the water supply pressure been checked to ensure a minimum of 0.07MPa (0.7 bar) and a maximum of 0.78MPa (7.8 bar)?  
 Note: The icemaker may stop running when the water supply is off, or if the pressure is below 0.07MPa (0.7 bar). When the proper water pressure is reached, the icemaker automatically starts running again.
- 9) Are the compressor hold-down bolts snug? Have the refrigerant lines been checked to make sure they do not rub or touch other lines or surfaces? Have the fan blade(s) (if applicable) been checked to make sure they turn freely?
- 10) On remote air-cooled model, is the refrigerant line set tightened and free of leaks and kinks?
- 11) On remote air-cooled model, has the icemaker power supply been on for a minimum of 4 hours?
- 12) Has the end user been given the instruction manual, and instructed on how to operate the icemaker and the importance of the recommended periodic maintenance? Upon completion of startup, this installation manual should also be given to the end user.
- 13) Has the end user been given the name and telephone number of an authorized service agent?
- 14) Has the warranty card been filled out and forwarded to the factory for warranty registration?

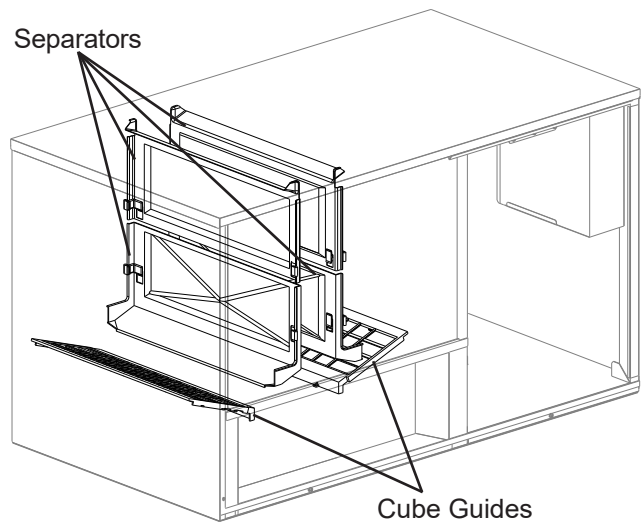

**Fig. 19**

**J. Startup**

**⚠ WARNING**

1. All parts are factory-adjusted. Improper adjustments may adversely affect safety, performance, component life, and warranty coverage.
2. If the icemaker is turned off, wait for at least 3 minutes before restarting the icemaker to prevent damage to the compressor.
3. To prevent damage to the water pump, do not leave the control switch in the "WASH" position for extended periods of time when the water tank is empty.
4. On remote air-cooled model, the icemaker should have power for a minimum of 4 hours prior to startup to prevent compressor damage.
5. At startup, confirm that all internal and external connections are free of leaks.

- 1) Open the water supply line shut-off valve(s).
- 2) Remove the front panel.
- 3) Move the control switch on the control box to the "ICE" position.
- 4) Replace the front panel in its correct position.
- 5) Turn on the power supply, and allow the icemaker to operate for a total of 10 minutes.
- 6) Turn off the power supply, then remove the front panel.
- 7) Remove the insulation panel. Remove the drain plug located on the lower front part of the ice chute. See Fig. 20. Allow the water tank to drain.
- 8) Replace the drain plug, insulation panel, and front panel in their correct positions. Be careful not to cross thread the drain plug.
- 9) Clean the storage bin liner using a neutral cleaner. Rinse thoroughly after cleaning.
- 10) Turn on the power supply to start the automatic icemaking process.
- 11) To confirm bin control operation, press and hold the bin control's actuator paddle during the first 5 minutes of the freeze cycle. The icemaker should shut down in approximately 15 seconds.
- 12) On water-cooled model, confirm proper condenser drain outlet/return outlet temperature as outlined in "II.H.2. Water-Cooled Condenser."

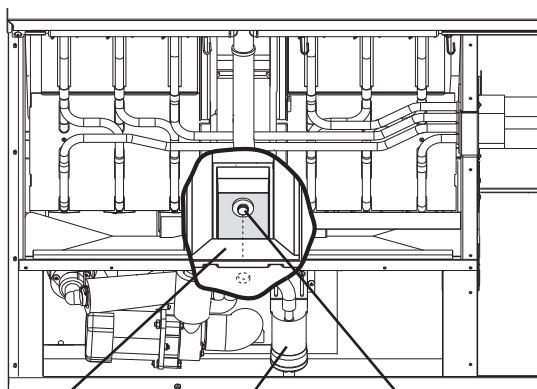

**Fig. 20**

Ice Chute    Float Switch Assembly    Drain Plug

**III. Cleaning and Maintenance Instructions**

This icemaker must be cleaned and maintained in accordance with the documentation and labels provided with the icemaker. Consult with your local distributor about cleaning and maintenance service. To obtain the name and phone number of your local distributor, contact your nearest Hoshizaki Service office.

**⚠ WARNING**

1. Except as specified below, only qualified service technicians should attempt to service this icemaker.
2. **CHOKING HAZARD:** Ensure all components, fasteners, and thumbscrews are securely in place after any cleaning or maintenance is done to the unit. Make sure that none have fallen into the storage bin.
3. This appliance must not be cleaned by use of a water jet.
4. To prevent possible damage, do not clean the plastic parts with water above 40°C or in a dishwasher.
5. The storage bin is for ice use only. Do not store anything else in the storage bin.

**A. Cleaning and Sanitizing Instructions**

**Performed by Qualified Service Technician**

Hoshizaki recommends cleaning and sanitizing this unit at least once a year. More frequent cleaning and sanitizing, however, may be required in some existing water conditions.

**⚠ WARNING**

1. To prevent injury to individuals and damage to the icemaker, do not use ammonia type cleaners.
2. Carefully follow any instructions provided with the bottles of cleaning and sanitizing solution.
3. Always wear liquid-proof gloves and goggles to prevent the cleaning and sanitizing solutions from coming into contact with skin or eyes.
4. To prevent damage to the water pump seal, do not operate the icemaker with the control switch in the "WASH" position when the water tank is empty.

**IMPORTANT**

1. The cleaning valve is opened during cleaning and sanitizing to allow solution flow to the inside of the evaporator. It should be closed for all icemaking operation. The compressor will not operate unless this valve is completely closed.
2. To close the cleaning valve, the valve handle should be at a right angle to the valve body. To open the cleaning valve, the valve handle should be parallel to the valve body.

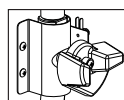

**CLOSED**  
Icemaking Operation

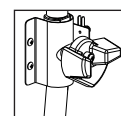

**OPEN**  
Cleaning and Sanitizing Operation  
(allows solution flow to the inside of the evaporator)



## 1. Cleaning Procedure

- 1) Dilute 800 ml of Hoshizaki "Scale Away" with 19 l of warm water or prepare the other recommended Hoshizaki sanitizer as directed..
- 2) Remove all ice from the evaporator and the storage bin.  
Note: To remove cubes on the evaporator, turn off the power supply and turn it back on after 3 minutes. The harvest cycle starts and the cubes will be removed from the evaporator.
- 3) Turn off the power supply.
- 4) Remove the front panel, then remove the insulation panel by first removing the thumbscrew, lifting up the panel slightly and pulling it towards you.
- 5) Remove the drain plug located on the lower front part of the ice chute. See Fig. 20. Allow the water tank to drain.
- 6) Replace the drain plug in its correct position. Be careful not to cross thread it.
- 7) In bad or severe water conditions, clean the float switch assembly as described below. Otherwise, continue to step 8.
  - a. Disconnect the vent tube and the flush tube from the top of the float switch, then remove the float switch assembly. Remove the rubber boot from the bottom of the assembly.
  - b. Remove the retainer rod from the bottom of the float switch housing, then remove the float. Be careful not to bend the retainer rod excessively when removing it.
  - c. Wipe down the float switch assembly's housing, shaft, float, and retainer rod with cleaning solution. Clean the inside of the rubber boot and hose with cleaning solution. Rinse the parts thoroughly with clean water.
  - d. Reassemble the float switch assembly and replace it and the rubber boot in their correct positions. Reconnect the vent tube and the flush tube.
- 8) Pour the cleaning solution into the water tank.
- 9) Move the control switch on the control box to the "WASH" position.
- 10) Replace the insulation panel and the front panel in their correct positions.
- 11) Turn on the power supply to start the washing process.
- 12) Turn off the power supply after 30 minutes.
- 13) Remove the front panel and the insulation panel.
- 14) Remove the drain plug. Allow the water tank to drain. Replace the drain plug and the insulation panel in their correct positions.
- 15) Move the control switch to the "ICE" position.
- 16) Replace the front panel in its correct position.
- 17) Turn on the power supply to fill the water tank with water.
- 18) Turn off the power supply after 3 minutes.
- 19) Remove the front panel.
- 20) Move the control switch to the "WASH" position.
- 21) Replace the front panel in its correct position.
- 22) Turn on the power supply to rinse off the cleaning solution.
- 23) Turn off the power supply after 5 minutes.
- 24) Remove the front panel and the insulation panel.

- 25) Remove the drain plug. Allow the water tank to drain. Replace the drain plug and the insulation panel in their correct positions.  
Note: Do not replace the insulation panel when you proceed to "2. Sanitizing Procedure."
- 26) Repeat steps 15 through 25 three more times to rinse thoroughly.  
Note: If you do not sanitize the icemaker, go to step 9 in "2. Sanitizing Procedure."

## 2. Sanitizing Procedure - Following Cleaning Procedure

- 1) Dilute 74 ml or 5 tbs of a 5.25% sodium hypochlorite solution (chlorine bleach) with 19 l of warm water.
- 2) Pour the sanitizing solution into the water tank.
- 3) Replace the insulation panel and the front panel in their correct positions.  
Note: Make sure the control switch is in the "WASH" position.
- 4) Turn on the power supply to start the sanitizing process.
- 5) Turn off the power supply after 15 minutes.
- 6) Remove the front panel and the insulation panel.
- 7) Remove the drain plug. Allow the water tank to drain. Replace the drain plug and the insulation panel in their correct positions.
- 8) Repeat steps 15 through 25 in "1. Cleaning Procedure" two times to rinse thoroughly.
- 9) Move the control switch to the "ICE" position.
- 10) Replace the front panel in its correct position.
- 11) Clean the storage bin liner using a neutral cleaner. Rinse thoroughly after cleaning.
- 12) Turn on the power supply to start the automatic icemaking process.

## B. Maintenance

The maintenance schedule below is a guideline. More frequent maintenance may be required depending on water quality, the icemaker's environment, and local sanitation regulations.

### ⚠ WARNING

1. Except as specified below, only qualified service technicians should attempt to service this icemaker.
2. Move the power switch to the "OFF" position and disconnect power before servicing.

### 1. Stainless Steel Exterior - Performed by Qualified Service Technician or Owner/Manager

To prevent corrosion, wipe the exterior occasionally with a clean, soft cloth. Use a damp cloth containing a neutral cleaner to wipe off oil or dirt buildup.

### 2. Storage Bin and Scoop - Performed by Qualified Service Technician or Owner/Manager

Clean the scoop and the storage bin liner using a neutral cleaner. Rinse thoroughly after cleaning.

### 3. Air Filters (air-cooled model) - Performed by Qualified Service Technician or Owner/Manager

Plastic mesh air filters remove dirt and dust from the air and keep the condenser from getting clogged. As the filters get clogged, the icemaker's performance will be

reduced. Check the filters at least twice a month. When clogged, use warm water and a neutral cleaner to wash the filters.

**4. Condenser (air-cooled and remote air-cooled models) - Performed by Qualified Service Technician**

The condenser should be checked and cleaned once a year. Instructions for the service technician can be found in the Installation Manual supplied with this icemaker.

**C. Preparing the Icemaker for Long Storage Performed by Qualified Service Technician**

**CAUTION**

1. When storing the icemaker for an extended time or in sub-freezing temperatures, follow the instructions below to prevent damage.
2. To prevent damage to the water pump seal, do not operate the icemaker with the control switch in the "WASH" position when the water tank is empty.

When the icemaker is not used for two or three days under normal conditions, it is sufficient to move the control switch to the "OFF" position. When storing the icemaker for an extended time or in sub-freezing temperatures, follow the instructions below.

**1. Remove the water from the icemaker water supply line:**

- 1) Turn off the power supply, then remove the front panel.
- 2) Move the control switch on the control box to the "OFF" position.
- 3) Close the icemaker water supply line shut-off valve, then open the icemaker water supply line drain valve.
- 4) Allow the line to drain by gravity.
- 5) Attach a compressed air or carbon dioxide supply to the icemaker water supply line drain valve.
- 6) Move the control switch to the "ICE" position.
- 7) Replace the front panel in its correct position, then turn on the power supply.
- 8) Blow the icemaker water supply line out using the compressed air or carbon dioxide supply.
- 9) Close the icemaker water supply line drain valve.

**2. Drain the water tank:**

- 1) Turn off the power supply, then remove the front panel. Move the control switch to the "OFF" position.
- 2) Remove the insulation panel. Remove the drain plug located on the lower front part of the ice chute. See Fig. 20. Allow the water tank to drain.
- 3) Replace the drain plug and the insulation panel in their correct positions. Be careful not to cross thread the drain plug.
- 4) Remove all ice from the storage bin. Clean the storage bin using a neutral cleaner. Rinse thoroughly after cleaning.
- 5) Replace the front panel in its correct position.

**3. On water-cooled model, remove the water from the water-cooled condenser:**

- 1) Make sure the power supply is off, then remove the front panel and right side panel.
- 2) Close the condenser water supply line shut-off valve. If connected to a closed loop system, also close the condenser return line shut-off valve.
- 3) Open the condenser water supply line drain valve. If connected to a closed loop system, also open the condenser return line drain valve.
- 4) Attach a compressed air or carbon dioxide supply to the condenser water supply line drain valve.
- 5) Open the water regulating valve by using a screwdriver to pry up on the spring retainer underneath the spring. While holding the valve open, blow out the condenser using the compressed air or carbon dioxide supply until water stops coming out.
- 6) Close the drain valve(s).
- 7) Replace the right side panel and front panel in their correct positions.

**IV. WARRANTY**

Hoshizaki warrants to the original owner/user that all Hoshizaki branded products shall be free of defects in material and/or workmanship for the duration of the "warranty period". The warranty shall be effective for three years from the date of installation.

Hoshizaki's liability under the terms of the warranty are limited and shall exclude routine servicing, cleaning, essential maintenance and/or repairs occasioned by misuse and installations not in accordance with Hoshizaki guidelines.

Warranty repairs should be completed by an approved Hoshizaki dealer or service agency using genuine Hoshizaki components.

To obtain full details of your warranty and approved service agency, please contact your dealer/supplier, or the nearest Hoshizaki Service office:

**V. DISPOSAL**

Comply with local regulations regarding disposal of this appliance and its refrigerant gas. Before you scrap the appliance, take off the door to prevent children trapped.

Correct disposal of this product:

This marking indicates that this product should not be disposed with other household wastes throughout the EU. To prevent possible harm to the environment or human health from uncontrolled waste disposal, recycle it responsibly to promote the sustainable reuse of material

resources. To return your used device, use the return and collection systems or contact the retailer where the product was purchased. They can take this product for environmental safe recycling.



**WARNING**



The insulation foaming agent used for the unit body contains flammable gas cyclopentane. With this in mind, dispose of the product properly.