

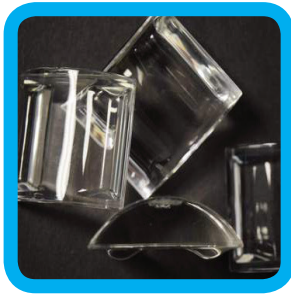

HOSHIZAKI

> KM-55B

Daily ice production capacity up to **53KG**



This KM series ice maker produces clear, crescent shaped ice that is extremely versatile. It includes a double-sided stainless steel evaporator, which requires fewer cycles to produce a full bin of ice, thereby reducing energy consumption.



CRESCENT ICEMAKER SERIES

FEATURES

- > Individual premium crescent cube with no ice bridging.
- > Exceptionally hard crystal clear cubes that melt slowly.
- > Slide in air filter at front for easy cleaning maintaining performance efficiency.
- > Double-sided stainless steel evaporator for all water conditions produces more ice in less cycles.
- > Snap in water tank design - easy to remove for sanitization.
- > Durable stainless steel exterior.
- > Low water electrical consumption.
- > Flush mount to rear wall.
- > Good in hard water areas.



ICE SIZE

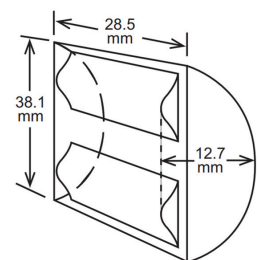

CERTIFICATION



DIMENSIONS & SPECIFICATION

TOP SIDE

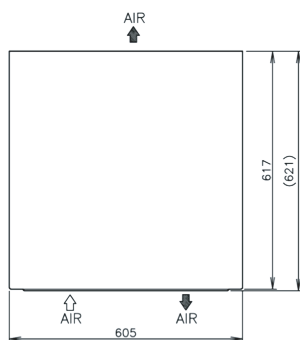

FRONT SIDE

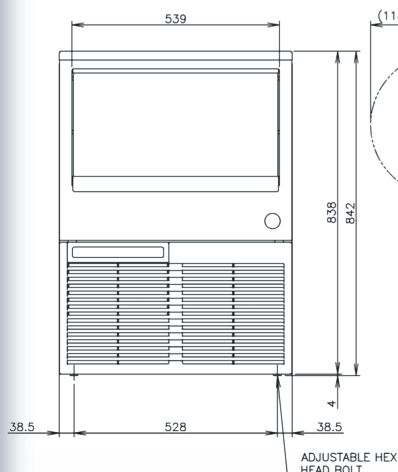

RIGHT SIDE

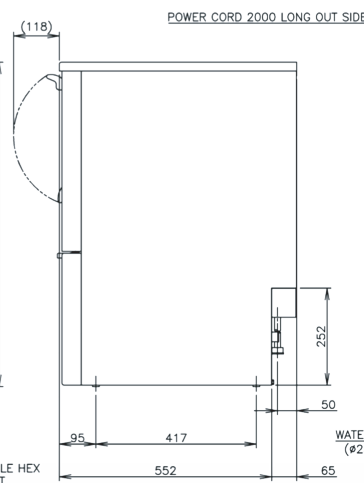

BACK SIDE

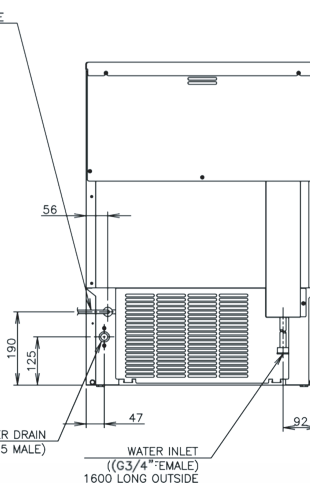

KM-55B		
ICE DIMENSIONS (WxDxH)	38.1 x 28.5 x 12.7 mm	
DIMENSIONS (WxDxH)	605 x 617 x 842 mm	
PACKAGE DIMENSIONS (WxDxH)	690 x 705 x 955 mm	
WEIGHT (NET/GROSS)	46 KG / 58 KG	
AMPERAGE / STARTING AMPERAGE	1.9 A / 15.5 A	
ELECTRICAL CONSUMPTION (AT32°C/WT21°C)	303 W	
REFRIGERANT CHARGE	R134a/ 210g	
HEAT REJECTION (AT32°C/WT21°C)	710 W (611 kcal/h)	
ICE PRODUCTION PER 24H (15MM)	(AT10°C/WT10°C)	53 KG
	(AT21°C/WT15°C)	50 KG
	(AT32°C/WT21°C)	41 KG
ICE PRODUCTION PER CYCLE (AT32°C/WT21°C)	Approx. 1.03 KG / 110 pcs FREEZE CYCLE TIME PER CYCLE 34 minutes	
WATER CONSUMPTION PER 24H (AT32°C/WT21°C)	0.07 m ³ ≈ 1.7 L / 1 KG ice	

NOTE:
All dimensions indicated are
Width x Depth x Height in mm
*60Hz units are available on request

OPERATING CONDITIONS:

• Voltage Range: 198V-254V • Ambient Temperature: 1°-40°C • Water Supply:
5°-35°C / 0.07-0.78 Mpa / 7.25-116 PSI • AC Supply Voltage: 1/220-240V / 50Hz