



HOSHIZAKI

- > **IM-45NE**
- > **IM-45NE-25**

Daily ice production capacity up to **44KG**



Cube ice is perfectly symmetrical and leaves a good impression with its hard, crystal clear quality that melts very slowly; allowing customers to enjoy their favourite drink longer, The IM series allows more flexibility of application with each range offering ice in variable sizes alongside a design for uncomplicated usage from start to finish.



CUBE ICE MAKER SERIES

FEATURES

- > smart computer board technology
- > slide-in air filter for easy cleaning
- > LED error indicator for easy diagnosis
- > stainless steel exterior provides a hygienic and high quality finish



UNIQUE ICE PRODUCTION SYSTEM

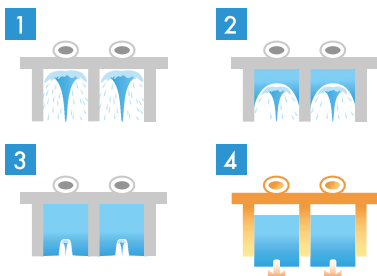

- > Individual cube
- > Impurity free
- > Hardest ice to enjoy slow melting and dilution of drinks

ICE SIZE

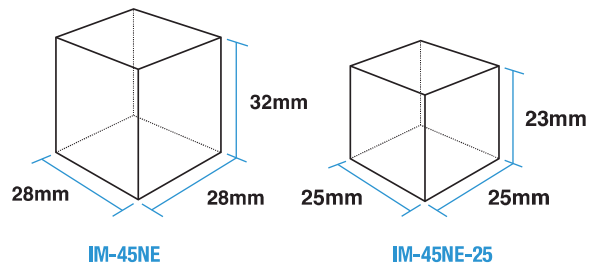

DIMENSIONS & SPECIFICATION

CUBE ICE MAKER AIR SYSTEM

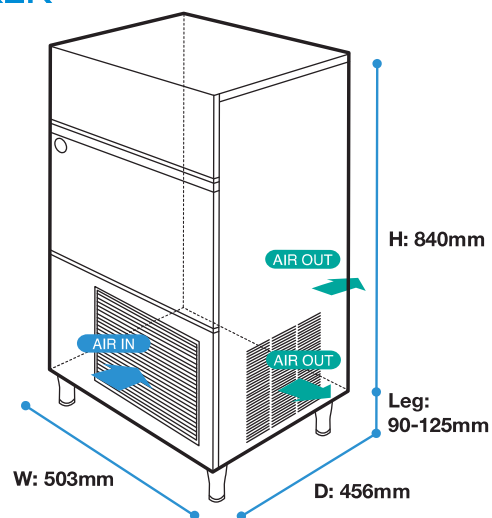
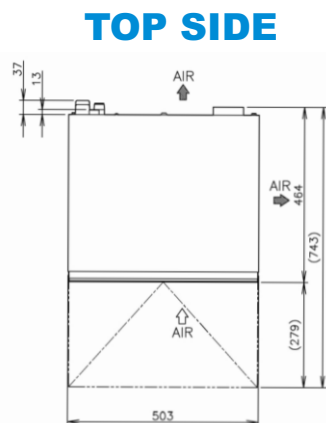

FRONT SIDE

RIGHT SIDE

BACK SIDE

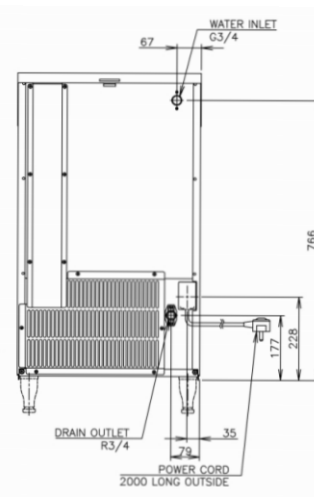
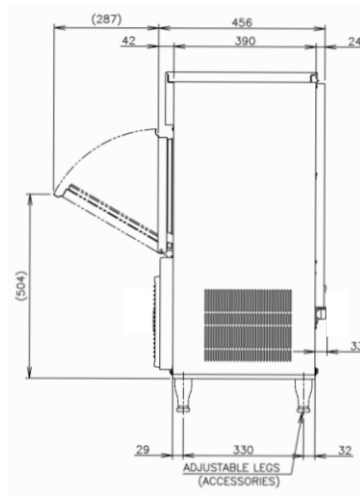
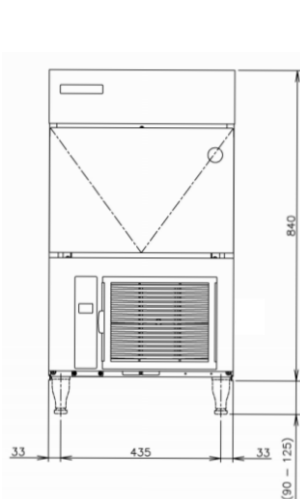

MODEL NAME		IM-45NE	IM-45NE-25
ICE DIMENSIONS (MM) (W x D x H)		28 x 28 x 32	25 x 25 x 23
DIMENSIONS (MM) (W x D x H)		Body : 503 x 456 x 840 / Leg Height : 90-125 mm	
PACKED DIMENSIONS (MM) (W x D x H)		635 x 520 x 1007	
WEIGHT (NETT/GROSS)		46 KG / 52 KG	
AMPERAGE / STARTING AMPERAGE		2.4A / 13A	
ELECTRICAL CONSUMPTION		330 W	
REFRIGERANT CHARGE		R134a	
HEAT REJECTION (AT32°C/WT21°C)		640 W (550 kcal/h)	
ICE PRODUCTION PER 24H (15MM)	(AT10°C/WT10°C)	44 KG	39 KG
	(AT21°C/WT15°C)	40 KG	35 KG
	(AT32°C/WT21°C)	32 KG	28 KG
WATER CONSUMPTION PER 24H (AT32°C/WT21°C)		0.09 m ³	0.10 m ³
		2.81L / 1KG ICE	3.57L / 1KG ICE
ICE PRODUCTION (AT32°C/WT21°C)	FREEZE CYCLE TIME	32 MIN	26 MIN
	PER CYCLE	0.67 KG / 30 PCS	0.55 KG / 42 PCS
STORAGE CAPACITY		18 KG	

• **WARRANTY:**

Two years parts & labour for entire unit, 3rd year on compressor only. Excluding door & exterior damages

• **OPERATING CONDITIONS:** • Voltage Range: 198V-254V • Ambient Temperature: 1°-40°C
 • Water Supply: 5°-35°C / 0.07-0.8 Mpa / 7.25-116 PSI • AC Supply Voltage: 1/220-240V / 50 Hz
 *60Hz units are available upon request

R1