



SELF-CONTAINED CUBER

IM-35M-2-LM
IM-55M-2-LM

INSTRUCTION MANUAL

HOSHIZAKI CORPORATION

3-16 Minamiyakata, Sakae-cho, Toyoake, Aichi 470-1194 Japan

L1M085101 (073120)

IMPORTANT

1. This booklet is an integral and essential part of the product and should be kept and preserved by the user. Please read carefully the guidelines and warnings contained herein as they are intended to provide the installer/user with essential information for the proper installation and the continued safe use and maintenance of the product. Please preserve this booklet for any further consultation that may be necessary.

2. This is a commercial icemaker, and should be destined only to be used for the purpose for which it has been expressly designed. Any other use should be considered improper and therefore dangerous. The manufacturer will not be held liable or responsible for any damage caused by improper, incorrect and unreasonable use.

CONTENTS

PAGE

I. GENERAL INFORMATION -----	1
1. SAFETY INSTRUCTIONS-----	1
2. CONSTRUCTION -----	4
[a] GENERAL -----	4
[b] OPERATION PANEL-----	6
[c] ACCESSORIES -----	7
[d] OPTIONS-----	8
3. CHECKS BEFORE OPERATION-----	8
[a] CHECKS AFTER INSTALLATION-----	8
[b] CHECKS BEFORE OPERATION -----	8
[c] WATER SUPPLY AND DRAIN CONNECTIONS -----	8
[d] AUTOMATIC ICEMAKING PROCESS -----	8
II. OPERATION-----	9
1. START UP -----	9
[a] START UP-----	9
[b] REMOVAL OF FRONT COVER -----	9
[c] DIMPLE SIZE ADJUSTMENT -----	10
2. SHUT DOWN -----	10
[a] SHUT DOWN-----	10
[b] PREPARING THE ICEMAKER FOR LONG STORAGE-----	11
III. MAINTENANCE AND INSPECTION -----	12
1. MAINTENANCE-----	12
[a] FOR SAFE HANDLING OF ICE -----	12
[b] SCOOP (DAILY) -----	12
[c] DOOR, DOOR HANDLE (DAILY)-----	13

[d] STORAGE BIN, SCOOP HOLDER, SLOPE, DOOR INTERIOR, DOOR GASKET, EXTERIOR (WEEKLY) -----	13
[e] AIR FILTER (BIWEEKLY)-----	14
2. INSPECTION -----	14
[a] SAFETY INSPECTION BY SERVICE PERSONNEL-----	14
[b] EARTH LEAKAGE CIRCUIT BREAKER (MONTHLY)-----	14
[c] ATTACHMENT PLUG (ANNUAL/BIANNUAL)-----	15
[d] WATER SUPPLY AND DRAIN CONNECTIONS (ANNUAL/BIANNUAL) -----	15
3. TROUBLESHOOTING-----	15
[a] TROUBLES REQUIRING CHECK BY USER -----	16
[b] TROUBLES REQUIRING IMMEDIATE SERVICE CALL-----	16
4. RELOCATION, DISPOSAL, TRANSFER-----	17
IV. INSTALLATION -----	18
1. UNPACKING AND CARRYING -----	18
2. INSTALLATION-----	19
3. ELECTRICAL CONNECTIONS -----	20
4. WATER SUPPLY AND DRAIN CONNECTIONS-----	21
5. TRIAL RUN-----	22

I. GENERAL INFORMATION

1. SAFETY INSTRUCTIONS

WARNING

1. To prevent possible water leak, electric shock or fire, the installation must be carried out by qualified personnel.
2. The unit must have a separate power supply. Branching off the Power Cord, using an extension cord, or sharing a single power supply with other appliances may result in electric shock, heat generation or fire. Use only one receptacle, even if an electrical outlet is provided with more than one.
3. This unit is not intended for outdoor use. Exposure to rain may cause electric leak or shock.
4. Do not install the unit where exposed to humidity or water splashes. Degradation of insulation may cause electric leak or shock.
5. Do not damage the Power Cord. It should not be additionally processed, jerked, bundled, weighed down or caught in. It could cause electric shock or fire.
6. To prevent electric shock, do not touch the Attachment Plug, Power Switch (Earth Leakage Circuit Breaker), or other electrical parts with damp hands.
7. Check that the Attachment Plug Blades are free of dust and that the Attachment Plug is securely plugged into the receptacle. Dusty blades or loose connection may cause electric shock or fire.
8. In case of a gas leak, turn off the gas and ventilate the room. To avoid the risk of ignition and explosion, do not touch or unplug the unit.
9. To prevent injury, do not put objects or hands in the icemaking compartment.
10. Do not hang or step on the Door or put heavy things exceeding 25 kg. The Door may fall off or the unit could tip over.
11. To prevent fire, electric shock, injury or water leak, this unit should be disassembled, repaired or modified only by qualified service personnel.
12. Do not splash water directly onto the unit. It may cause a short circuit, electric shock, corrosion or failure.
13. If the Power Switch (Earth Leakage Circuit Breaker) turns off, contact an authorized Hoshizaki service company. To prevent electric shock or fire, do not turn it back on.

14. In case of trouble (ex. burning smell), disconnect the main power supply, and immediately contact an authorized Hoshizaki service company. To prevent possible electric shock or fire, do not keep the unit in operation.
15. When shutting down the unit for temporary storage, keep the Door from shutting tight. Children could be shut in.
16. In case of relocation, contact an authorized Hoshizaki service company. Improper installation may cause water leak, electric shock or fire.
17. When disposing of the unit, contact an authorized Hoshizaki service company. Leaving the unit may be illegal or cause an unexpected accident.

CAUTION

1. To avoid possible health problems, use only tap water.
2. Do not use a water purifier. It will remove chlorine from tap water and may cause bacterial growth, resulting in health problems.
3. To prevent water leaks resulting in damage to the surrounding property, keep the water supply pressure within 0.05 to 0.78 MPa.
4. If there is a possibility that the ambient temperature may fall below 0°C and freeze the unit, be sure to drain the unit. The water supply line could be damaged and leak water, resulting in damage to the surrounding property.
5. To prevent melting of plastics, smoking or ignition, the unit should not be located on or next to high heat producing equipment (ex. gas cooking stove).
6. Do not put heavy things, water containing vessels or cartons on the unit (including the machine compartment). They could fall off and cause injury, or spilled water may degrade the electrical insulation and increase the risk of electric leak.
7. Do not use combustible spray or place volatile and flammable substances near the unit. They could catch fire from a spark of a switch or the like.
8. To prevent injury, do not hold the top of the Door Handle when closing the Door.
9. To avoid damage to the Door, do not kick the Door closed.
10. To keep away dust, insects and bacteria that may cause health problems, close the Door tightly until it clicks, and do not leave it open.
11. To prevent bacterial growth that may cause health problems, do not store anything other than ice and Scoop inside the Storage Bin.

12. If ice falls on the floor, put it away immediately to prevent slipping or stepping on.
13. Do not put anything into the air inlet/outlet. The Fan rotating rapidly inside may cause injury.
14. When removing the Front Cover, do not touch the Condenser Fins directly. It may cause injury.
15. To prevent bacterial growth that may cause health problems, clean the Scoop and Door every day and the Storage Bin every week.
16. Check the Earth Leakage Circuit Breaker for proper operation once a month. If it is left inoperable, it could increase the risk of electric shock in case of electric leak.
17. Check the drain pipe for clogging once or twice a year. Clogged pipe may leak water, resulting in damage to the surrounding property.
18. In case of low water, turn off the Power Switch (Earth Leakage Circuit Breaker) and close the Water Supply Line Shut-off Valve, or rusty water may flow in when water supply is resumed, resulting in impure ice production.
19. Before starting cleaning or inspection, turn off the Power Switch (Earth Leakage Circuit Breaker) and disconnect the main power supply to avoid possible electric shock or burn.
20. When shutting down the unit for more than a day, drain the unit to prevent water contamination which may cause bacterial growth, resulting in health problems.
21. When shutting down the unit for more than a week, turn off the Power Switch (Earth Leakage Circuit Breaker) and unplug the unit. Dust may collect on the Attachment Plug or receptacle and cause heat generation or ignition.
22. To unplug the unit, be sure to pull the Attachment Plug and do not jerk the Power Cord. It could be damaged and cause fire or electric shock.
23. Do not plug in/unplug the unit to start/stop the operation. It could cause electric shock or short circuit.
24. When selling or transferring this product, tape this Instruction Manual to the exterior to provide the new owner with information on safe and proper use of the product.

2. CONSTRUCTION

[a] GENERAL

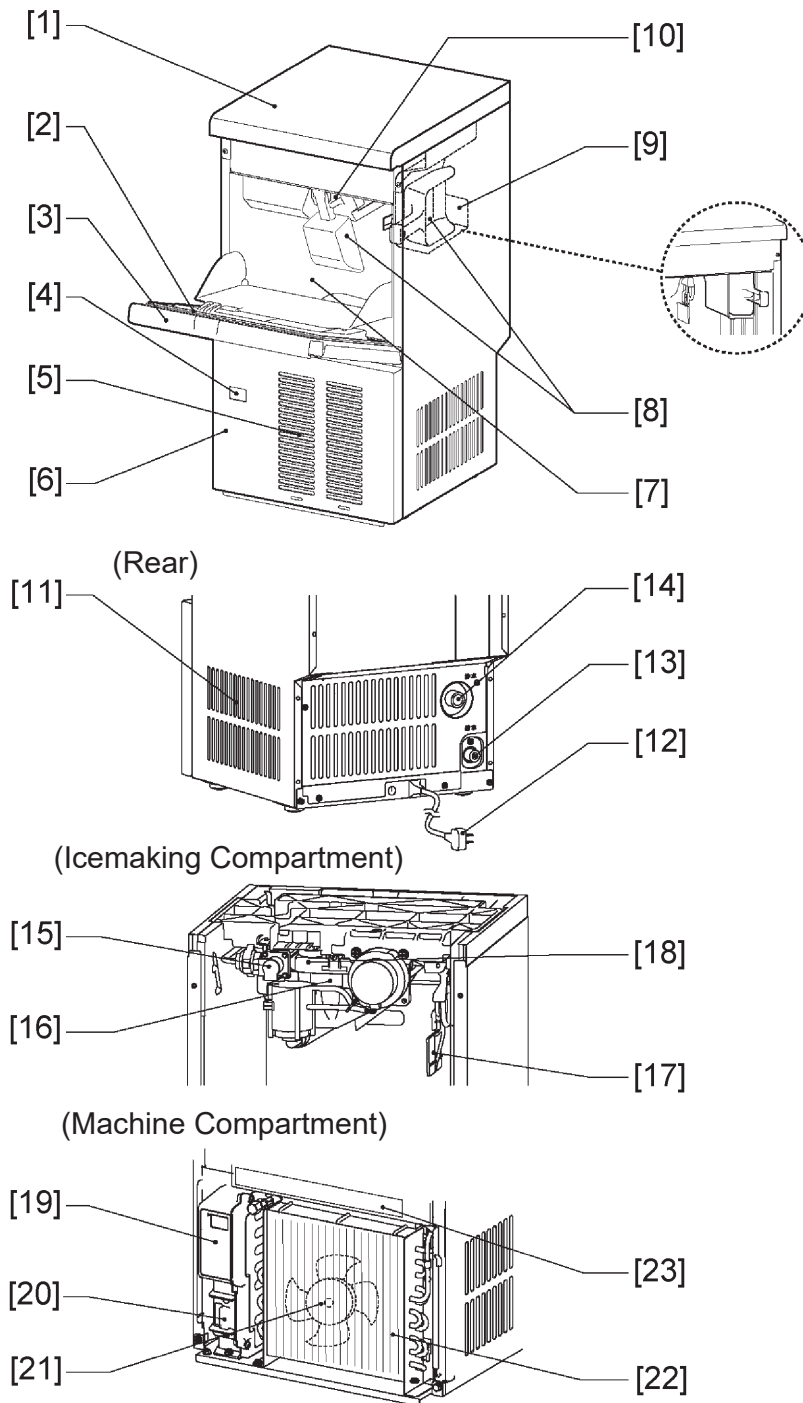

[1] Top Panel
Covers the icemaking compartment.

[2] Warning Label
Sanitation label.

- [3] Door, Handle
Provided with Door Gasket.
- [4] Display Window
The Operation Panel Display is visible.
- [5] Air Filter
Prevents the Condenser from clogging.
- [6] Front Cover
Covers the Control Box and Condenser.
- [7] Storage Bin
Stores ice.
- [8] Scoop (accessory)
Used to remove ice.
- [9] Scoop Holder (IM-55M-2-LM)
Holds the Scoop.
- [10] Scoop Holder (IM-35M-2-LM)
Hooks the Scoop.
- [11] Machine Compartment
Contains the refrigeration unit and electrical components.
- [12] Power Cord
1 phase 220V
- [13] Water Supply Inlet
R1/2
- [14] Drain Outlet
R3/4
- [15] Water Valve
Controls water supply.
- [16] Water Pan
Sprays water from the upper small holes into the Evaporator.
- [17] Bin Control Switch
Detects the Storage Bin is filled with ice and automatically stops the icemaking process.

[18] Evaporator

Cooled down to around -25°C to produce ice inside.

[19] Operation Panel

Provided with operation buttons and display. See “[b] OPERATION PANEL”.

[20] Power Switch (Earth Leakage Circuit Breaker)

Turns on and off the power supply.

[21] Condenser Fan

Cools the Condenser.

[22] Condenser

Cooled by the Fan to condense the refrigerant.

[23] Warning Label

Instruction label.

IMPORTANT





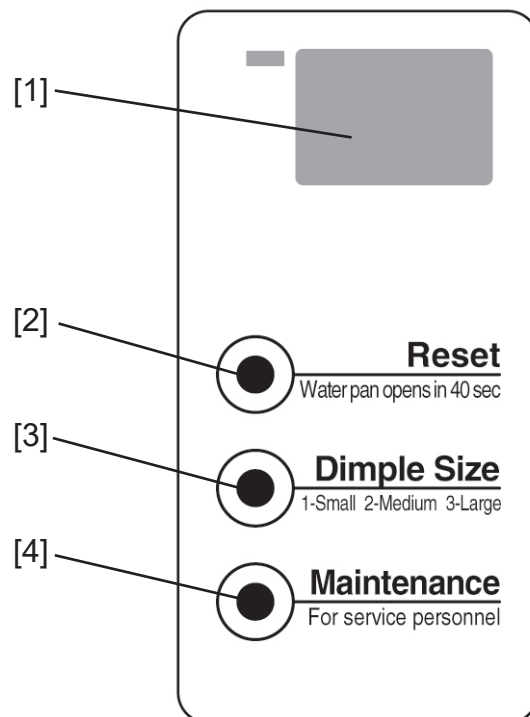





1. Do not remove the labels.
2. When any of the labels comes off or becomes illegible, contact an authorized Hoshizaki service company.

[b] OPERATION PANEL



[1] Display

Indicates the operating conditions.

Item	Indication
Power ON	 The letters "on" light up.
Freeze cycle	The number of illuminated bars shows percent complete.  ▶  ▶  0 - 30% 30 - 60% 60 - 100%
Defrost cycle	 The six bars light up.
Bin full	 The two bars in the middle light up.
Dimple size	   Small Medium Large
Error	 See "III. 3. [b] TROUBLES REQUIRING IMMEDIATE SERVICE CALL".

[2] Reset Button

Defrost cycle starts when this button is pressed down. The Water Pan opens in 40 seconds to drop ice.

[3] Dimple Size Button

Changes the dimple size in the center of ice cube. See "II. 1. [c] DIMPLE SIZE ADJUSTMENT".

[4] Maintenance Button

For service personnel only. Do not use.

[c] ACCESSORIES

Instruction Manual x 1
 Inlet Hose x 1

Scoop x 1
 Outlet Hose x 1

Adjustable Leg (100mm long) x 4
 Bushing x 1

[d] OPTIONS

Strainer x 1

IMPORTANT

When ordering an optional part, ask an authorized Hoshizaki service company for its installation.

3. CHECKS BEFORE OPERATION

[a] CHECKS AFTER INSTALLATION

* In the presence of the installer, check for proper installation according to “IV. INSTALLATION”.

[b] CHECKS BEFORE OPERATION

* Ambient temperature should be within 1 to 35°C and water temperature within 5 to 30°C. Do not install the unit where there is a possibility of freezing. If the ambient temperature exceeds 35°C, use a ventilator.

* Keep the Scoop in the Scoop Holder inside the Storage Bin.

IMPORTANT

1. Although the Storage Bin has been cleaned before shipment, clean it again before use. See “III. MAINTENANCE”.
2. When the unit is used for the first time or after more than a week, the Storage Bin interior or ice may smell. This is not harmful and will fade away while the unit is running. For sanitary reasons, discard the ice produced in the initial freeze cycle.

[c] WATER SUPPLY AND DRAIN CONNECTIONS

* The connections differ for each installation site. Check the locations of the Water Supply Line Shut-off Valve, Water Supply Valve and Drain Valve.

[d] AUTOMATIC ICEMAKING PROCESS

* When the Storage Bin is filled with ice and ice pushes the Bin Control Switch Lever, the unit will stop the icemaking process automatically. The Display will change to the “bin

full” indication.

- * When the ice level in the Storage Bin decreases and the Bin Control Switch Lever goes back to the original position, the unit will resume the icemaking process automatically.
- * When the Storage Bin fills up, move stored ice to the left side for maximum storage capacity.
- * Ice in the Storage Bin will melt gradually to become less clear and smooth, but will clear again in drinks.

II. OPERATION

1. START UP

[a] START UP

IMPORTANT

In case of low water, open the Drain Valve to drain rusty water before starting up the unit.

- 1) Open the Water Supply Line Shut-off Valve.
- 2) Open the Water Supply Valve.
- 3) Plug the unit into a separate outlet.
- 4) Remove the Front Cover.
- 5) Turn on the Power Switch (Earth Leakage Circuit Breaker). The Display will illuminate the letters “on”, and the unit will start the automatic icemaking process in 3 minutes.
- 6) Replace the Front Cover in its correct position.

[b] REMOVAL OF FRONT COVER

- 1) Lift up the Front Cover 1 cm and pull toward you.
- 2) To replace, fit the notch in the Front Cover against the tab on the frame, and pull down.

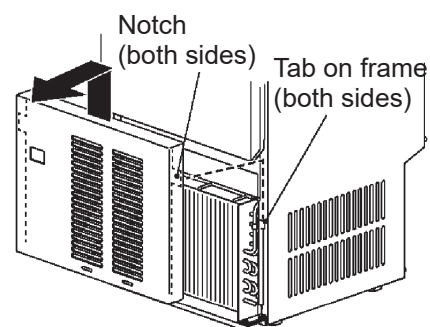

[c] DIMPLE SIZE ADJUSTMENT

* The dimple size is factory adjusted to “1” (small).

* When the dimple size is adjusted to “3” (large), the freeze cycle will be shorter and allow production of a large amount of ice in a short time.

- 1) Press the Dimple Size Button on the Operation Panel. The Display will show the current setting.
- 2) Keep pressing the Dimple Size Button to change the setting.

Dimple Size	1 - Small	2 - Medium	3 - Large
Freeze Cycle	Longer	←————→	Shorter

2. SHUT DOWN

[a] SHUT DOWN

IMPORTANT

In case of low water, follow the steps 1 through 4 below.

- 1) Close the Water Supply Line Shut-off Valve.
- 2) Remove the Front Cover, and press the Reset Button. See “1. [b] REMOVAL OF FRONT COVER”.
- 3) Open the Door, and push the Bin Control Switch Lever located in the back right side of the Storage Bin to the right for 60 seconds.
- 4) When the Display shows the “bin full” indication, turn off the Power Switch (Earth Leakage Circuit Breaker).
- 5) Unplug the unit.
- 6) Replace the Front Cover in its correct position. See “1. [b] REMOVAL OF FRONT COVER”.
- 7) Remove all ice from the Storage Bin, clean the interior and exterior, and dry well.

[b] PREPARING THE ICEMAKER FOR LONG STORAGE

IMPORTANT

1. When shutting down the unit for more than a day, drain the unit to prevent possible bacterial growth.
2. If there is a possibility of freezing, drain the unit.

- 1) Close the Water Supply Line Shut-off Valve.
- 2) Open the Drain Valve to drain the water circuit.
- 3) Connect a hose end (R1/2 for propane gas, available in gas appliance stores) to the drain outlet of the Drain Valve.
- 4) Connect a commercially available vinyl gas hose between the hose end and a foot pump (available in toy stores).
- 5) Remove the Front Cover, and press the Reset Button. See "1. [b] REMOVAL OF FRONT COVER".
- 6) After 15 seconds, use the foot pump to send in air from the water supply inlet to drain the internal water circuit.
- 7) Press the Reset Button. When the Water Pan opens in 40 seconds, turn off the Power Switch (Earth Leakage Circuit Breaker).
- 8) Unplug the unit.
- 9) Replace the Front Cover in its correct position. See "1. [b] REMOVAL OF FRONT COVER".
- 10) Remove all ice from the Storage Bin, clean the interior and exterior, and dry well.
- 11) Disconnect the hose end, and close the Water Supply Valve and Drain Valve.

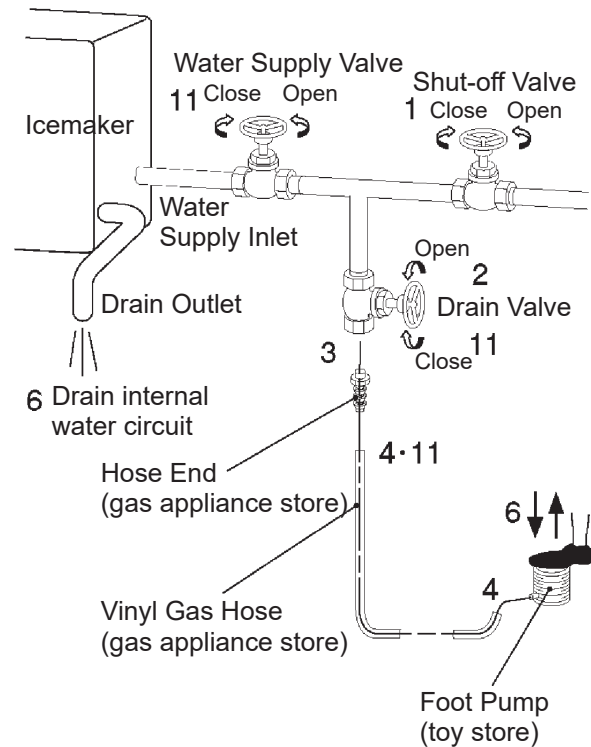

III. MAINTENANCE AND INSPECTION

1. MAINTENANCE

IMPORTANT

1. Always use clean hands and cloths to conduct cleaning operations.
2. Move ice into a clean container.
3. To prevent deformation of the plastic parts, do not wash the Scoop, Storage Bin and Air Filter in hot water above 40°C.
4. Invert soap is recommended for cleaning. Refer to the instruction manual of invert soap for its proper use.
5. Mix 1 L of warm water (30 - 40°C) with two caps (10 mL) of 10% invert soap (benzalkonium chloride) solution (available at pharmacies). Use a clean cloth containing the solution to wipe the unit thoroughly. After 5 minutes, use a cloth damped with cold or warm water to wipe off any remaining solution that may damage the metal or plastic surfaces.
6. To prevent damage to the painted or plastic surfaces, do not use thinner, benzine, alcohol, petroleum, soap powder, polishing powder, alkaline detergent, acid, scrub brush, and especially cleanser for use on fans and cooking ranges. Also, do not use any corrosive materials.
7. When using a chemical cloth, follow the instructions for use.
8. Remove heavy soil as required.

[a] FOR SAFE HANDLING OF ICE

- * To use ice for human consumption, daily maintenance and inspection are important.
- * When the icemaker is used for a long time, scale, mold or rust may mix in ice depending on temperature, water quality or aging. Especially, keep clean the Storage Bin interior by daily maintenance. If any foreign material is found at the bottom of the Storage Bin or in ice during operation or maintenance, stop using the icemaker, and immediately contact an authorized Hoshizaki service company.

[b] SCOOP (DAILY)

Soak in warm water (30 - 40°C) containing sodium hypochlorite for more than 3 minutes. Then rinse with tap water and wipe dry.

[c] DOOR, DOOR HANDLE (DAILY)

Always keep the Door and Door Handle clean because they are prone to bacterial contamination. Use a soft cloth containing warm water to wipe them clean.

The Door is made of stainless steel, but should be kept clean to prevent possible corrosion.

IMPORTANT

1. The Door has a painted surface. Do not use a commercially available stainless steel cleaner to avoid possible damage.
2. To prevent deformation or cracking, do not expose the plastic parts to pesticides or other oily materials.

[d] STORAGE BIN, SCOOP HOLDER, SLOPE, DOOR INTERIOR, DOOR GASKET, EXTERIOR (WEEKLY)

IMPORTANT

1. The Door has a painted surface. Do not use a commercially available stainless steel cleaner to avoid possible damage.
2. To prevent deformation or cracking, do not expose the plastic parts to pesticides or other oily materials.
3. Clean the Scoop Holder thoroughly to remove any dirt or dust (IM-55M-2-LM).

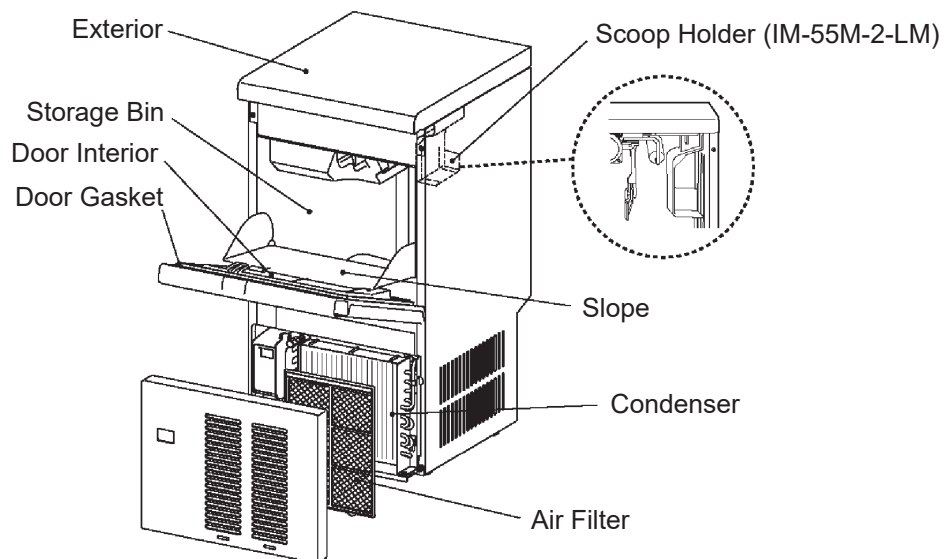

[e] AIR FILTER (BIWEEKLY)

- * If the Air Filter is clogged with dirt or dust, the icemaker cannot operate properly.
- * Do not operate the icemaker with the Air Filter removed. Dust may come into the unit, resulting in failure.

- 1) Remove the Front Cover. Pull the Air Filter toward you, and lift it off. See “1. [b] REMOVAL OF FRONT COVER”.
- 2) Dilute a neutral detergent in cold or warm water. Wash the Air Filter carefully not to break the mesh. Rinse and dry well.
- 3) Fit the tab at the Air Filter bottom into the hole in the Front Cover, and fix the Air Filter in place with the magnet at the top.

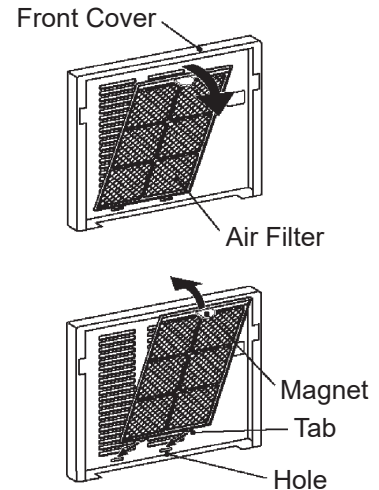

2. INSPECTION

[a] SAFETY INSPECTION BY SERVICE PERSONNEL

Even if there is no problem with its use, a product out of warranty may have a risk of electric shock, fire, or water leak due to insulation degradation or aging of the electrical parts. Ask an authorized Hoshizaki service company for the following inspections (charged):

- * Dust and dirt buildup or water leak inside the unit
- * Aging conditions of the unit and its components
- * Scale, silica, lime or other foreign matter in the water circuit

[b] EARTH LEAKAGE CIRCUIT BREAKER (MONTHLY)

Open the Front Cover, and press the Test Button with the tip of a ball-point pen or the like. The lever must move to the “OFF” position.

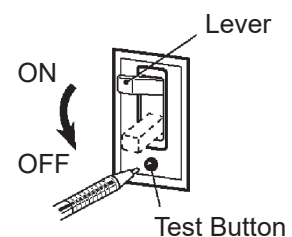

IMPORTANT

If the lever does not move to the “OFF” position, immediately contact an authorized Hoshizaki service company.

[c] ATTACHMENT PLUG (ANNUAL/BIANNUAL)

Check the Attachment Plug and Power Cord to see if:

- * The Attachment Plug and Power Cord are not overheated, damaged, weighed down or caught in. In case of any trouble, immediately contact an authorized Hoshizaki service company and ask for a repair.
- * The Attachment Plug Blades and their vicinity and the receptacle are free of dust. Clean them if necessary.
- * The Attachment Plug is plugged into a separate receptacle.

[d] WATER SUPPLY AND DRAIN CONNECTIONS (ANNUAL/BIANNUAL)

- * Check that the water supply and drain connections are free of water leaks and not weighed down by heavy things.
- * If the drain pipe clogs, water will overflow onto the floor. Pour about 2 L of water into the empty Storage Bin, and check that the water drains out within 1 minute.

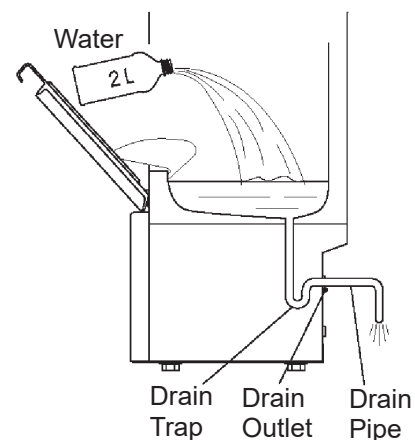

IMPORTANT

In case of water leaks or clogged drain pipe, immediately contact an authorized Hoshizaki service company.

3. TROUBLESHOOTING

- * If something seems wrong with the unit, follow the instructions below before calling for service.
- * When contacting an authorized Hoshizaki service company, let them know the model name, serial number, date of installation (see warranty card) and state of the trouble.
- * Do not attempt to repair the unit by yourself.

[a] TROUBLES REQUIRING CHECK BY USER

When one of the following problems occurs, check for possible causes. If the problem cannot be solved, immediately contact an authorized Hoshizaki service company.

Problem	Possible Cause
Abnormal noise	Operational, water supply, water circulation, and ice dropping sounds may be heard during normal operation.
Condensation on exterior	Interior temperature is low. Wipe off with a soft cloth.
No ice production	Unplugged.
	Power failure.
	Power Switch (Earth Leakage Circuit Breaker) is OFF. Immediately contact an authorized Hoshizaki service company.
	Display is flashing error code "E1" - "EC".
Slow ice production	Ambient temperature exceeds 35°C.
	Affected by external heat source.
	Air flow is blocked by object in front of Front Cover.
	Air Filter is not clean.
Cloudy ice	Water quality.
Incomplete ice production with large dimple	Power failure.
	Power Switch (Earth Leakage Circuit Breaker) was turned OFF and ON during operation.
	Reset Button was pressed during operation.
	Water supply pressure is too low.
	Ambient temperature exceeds 35°C.
	Affected by external heat source.
	Air flow is blocked by object in front of Front Cover.
	Air Filter is not clean.
Water leaks	Drain Pipe or Trap is clogged.
	Drain Pipe is bent and crushed.
	Drain Pipe is located higher than drain outlet.
	Drain Pipe is directly connected to sewer system.

[b] TROUBLES REQUIRING IMMEDIATE SERVICE CALL

When the Display flashes one of the following error codes, immediately contact an authorized Hoshizaki service company.

Error Code	Error	Problem
E1	Abnormal freeze cycle	Freeze cycle takes longer than set time.
E2	Abnormal defrost cycle	Defrost cycle takes longer than set time.
E3	Water Pan opening failure	Water Pan will not open.
E4	Water Pan closing failure	Water Pan will not close.
E5	Evaporator temperature too high	Defrost cycle will not stop.
E7	Fan Motor failure	Fan Motor will not run.
E8	Pump Motor failure	Pump Motor will not run.
EA	EEPROM error	Controller Board is defective.
EC	Cube Control Thermistor failure	Cube Control Thermistor has short or open circuit.

4. RELOCATION, DISPOSAL, TRANSFER

WARNING

1. In case of relocation, contact an authorized Hoshizaki service company. Improper installation may cause water leak, electric shock or fire.
2. When disposing of the unit, contact an authorized Hoshizaki service company. Leaving the unit may violate laws or cause an unexpected accident.

CAUTION

When selling or transferring this product, tape this Instruction Manual to the exterior to provide the new owner with information on safe and proper use of the product.

IV. INSTALLATION

WARNING

The installation must be carried out by qualified personnel according to this manual. On completion of the installation, start up the unit to check for any abnormalities, and instruct the user on how to use and maintain the unit in accordance with the Instruction Manual.

1. UNPACKING AND CARRYING

WARNING

1. To prevent injuries, unpack the unit on a firm and level foundation.
2. When carrying the unit, do not hold the Top Panel or Door. They may come off and cause injuries.

CAUTION

1. To prevent injuries, remove the Front Cover, and carry the unit by holding its bottom.
2. Do not carry the carton by holding shipping bands. They may break and cause injuries.

IMPORTANT

To avoid possible damage to the Compressor, do not tilt the unit more than 45°.

* Remove shipping tapes from the exterior and interior (ex. Bin Control Switch in Storage Bin).

* Remove the protective plastic film from the exterior. If the icemaker is exposed to the sun or heat, remove the film after the icemaker cools.

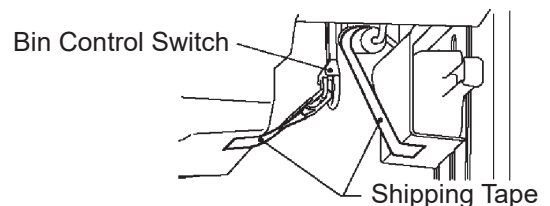

IMPORTANT

Do not remove the labels.

* Check that all the exterior (ex. Front Cover) and interior parts as well as the listed accessories are provided without damage.

IMPORTANT

If any part is found damaged or missing, contact an authorized Hoshizaki service company.

2. INSTALLATION

CAUTION

1. The location should provide a firm and level foundation for the unit to avoid the risk of water leaks or injury caused by overturn or fall.
2. Avoid a site where dripping is not allowed. In high humidity conditions, condensation on the exterior may drip onto the floor.

IMPORTANT

1. Ambient temperature should be within 1 to 35°C.
2. The unit should not be exposed to direct sunlight or located next to high heat producing equipment (ex. cooking stove).
3. Allow 10 mm extra space at the installation site to meet any installation requirements (additional spacing is also required for proper air flow and water connections).

* Allow the following clearance between the unit and the surrounding walls or objects. Do not block the machine compartment to ensure good ventilation. Insufficient clearance may cause poor heat rejection, resulting in reduction of ice production or failure.

Either corner or alcove installation is available.

(Alcove installation will slightly reduce the ice production.)

[Corner installation]

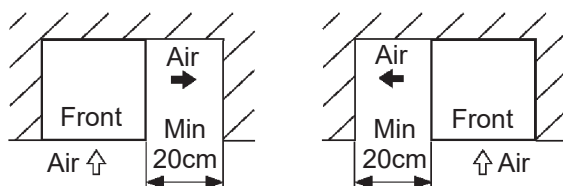

[Alcove installation]

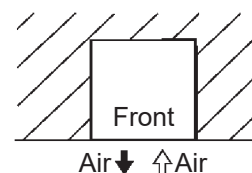

- * Use the Adjust Bolts at the bottom to level the unit.
- * To attach the accessory Adjustable Legs (100mm long), replace the Adjust Bolts at the bottom with the four Adjustable Legs provided, and adjust them to level the unit.

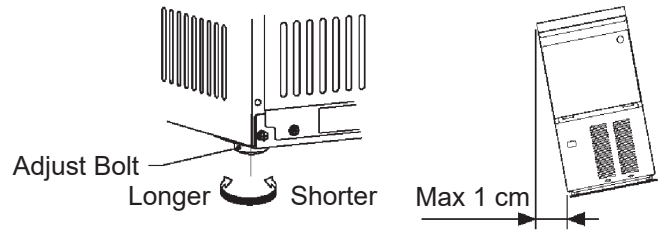

3. ELECTRICAL CONNECTIONS

WARNING

1. The connections must be made to a separate power supply or receptacle in accordance with the national and local electrical code requirements and this Instruction Manual. Improper connections may cause electric shock or fire.
2. Disconnect the main power supply before making any electrical connections to prevent possible electric shock. Attach a sign to warn against turning on the power supply during the electrical work.

CAUTION

The maximum allowable voltage variation should not exceed ± 10 percent of the rated voltage. Operation of the unit outside of this range may cause smoking, ignition, damage to the unit or reduction of the performance.

- * The main power supply (circuit breaker) and receptacle must have a capacity of not less than 2.3A (IM-35M-2-LM) or 3.3A (IM-55M-2-LM).

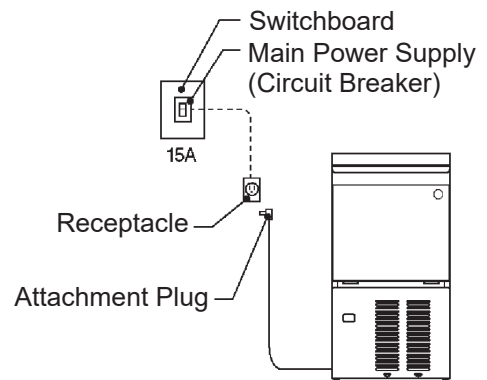

4. WATER SUPPLY AND DRAIN CONNECTIONS

* Be sure to use tap water.

IMPORTANT

1. Depending on water quality, even tap water may cause scaling inside the water circuit, resulting in reduction of ice production or failure. Use tap water with a maximum hardness of 50 mg/L and a maximum silica content of 30 mg/L.
2. Use of tap water exceeding the above limits will require installation of a water treatment device suitable for such water quality. Consult with a water treatment specialist or an authorized Hoshizaki service company.

* The water supply line should be a flexible, rigid PVC, or rigid PVC lined steel pipe in compliance with the applicable water quality standards.

* The drain line should be a rigid PVC pipe.

* Clean the pipes thoroughly before connections to remove shavings, cutting oils, or other foreign matter that may clog the Filter or Water Valve.

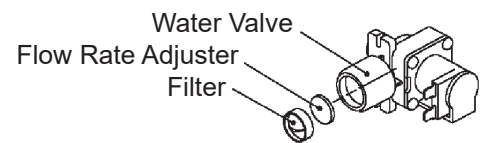

* When removing the Filter from the Water Valve, be careful not to lose the Flow Rate Adjuster.

* Use sealants, sealing tapes, or gaskets to have leak free joints. Do not use a sealant that can clog the pipes or leave the odor in water.

* The drain pipe should be as short and straight as possible, sloped downward, and always located below the drain outlet.

* To prevent backflow, do not connect the drain pipe directly to the sewer system. Keep more than 5 cm air gap between the pipe end and the sewer. (Since a U-trap is provided inside the unit, no external U-trap is required.)

* Do not let water drain directly onto the floor before running into the sewer. Foreign matter on the floor may mix into the water and clog the sewer, or the water could run in a wrong direction.

* After connections, check them according to "III. 2. [d] WATER SUPPLY AND DRAIN CONNECTIONS (ANNUAL/BIANNUAL)".

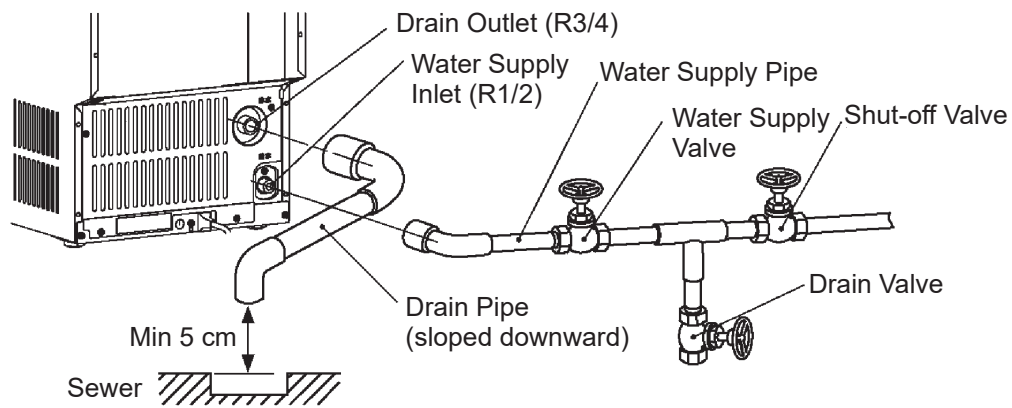

Connections with accessory Inlet and Outlet Hoses

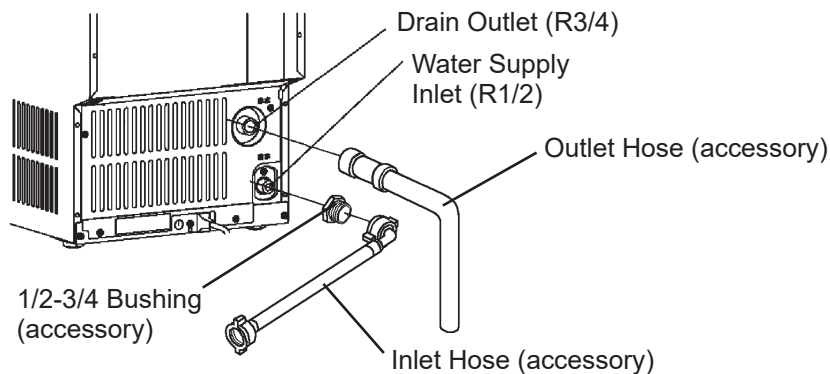

5. TRIAL RUN

After installation, check the unit for proper operation as follows:

- 1) Check the supply voltage. Is a separate receptacle of 1 phase 220V used?
- 2) Plug in the unit. Is the unit securely plugged in?
- 3) Close the Drain Valve, and open the Water Supply Line Shut-off Valve. Is water supplied to the unit? Are there any water leaks in the water supply line or drain line?
- 4) Turn on the Power Switch. Does the unit start up in 3 minutes?
- 5) Wait for 20 - 30 minutes, and check for proper ice production. Does ice drop into the Storage Bin? Is there any abnormal noise? Is ice produced properly?
- 6) Instruct the user on proper operation.
- 7) Discard ice produced during trial run.
- 8) Clean inside the Storage Bin.
- 9) Hand over the Instruction Manual to the user.