



# HOSHIZAKI



## > FM-600AKE

flake ice

daily ice production capacity of up to **600KG**



## > FM-600AKE-N

nugget ice

daily ice production capacity of up to **530KG**



(With Hoshizaki Storage Bin - **B301SA**)

FLAKE ICE MAKER SERIES

Apart from drinks, ice is important for preservation. Hoshizaki's FM ice machines produce flakes that are 70% ice and 30% water and are primarily used for cooling purposes. It is also used in large facilities such as in healthcare, catering, supermarket chains or even cocktail bars.

## FEATURES

- > Auger is made of doublehardened stainless steel. Combined with carbon bearings, they work optimally in a tough and wet environment. Benefits include longer product life expectancy and reduced maintenance costs.
- > 100% hfc free CO2 foam insulation maintains consistent temperature
- > smart computer board technology
- > stainless steel exterior
- > led error indicator for easy diagnosis

## UNIQUE ICE PRODUCTION SYSTEM

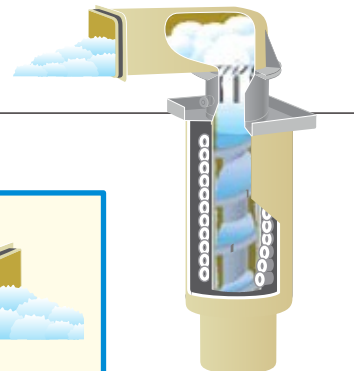
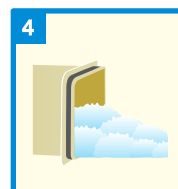
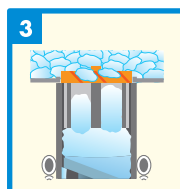
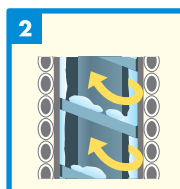
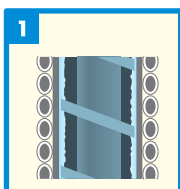

# DIMENSIONS & SPECIFICATION

## FLAKE ICE MAKER AIR SYSTEM

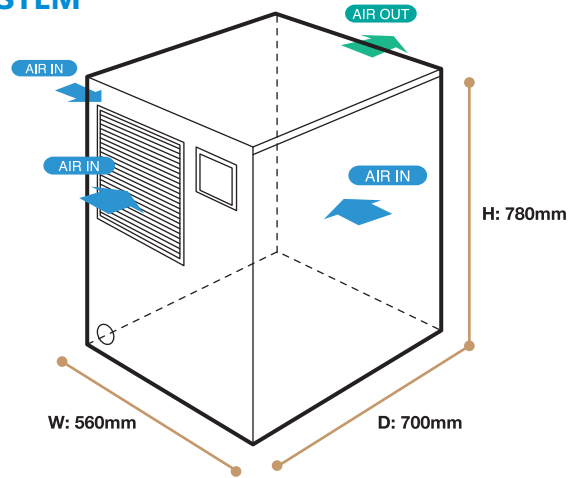
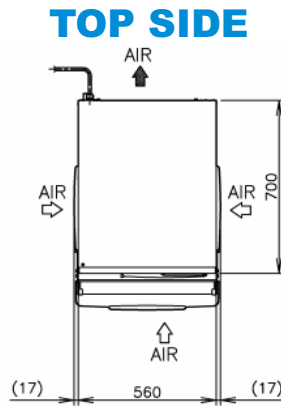

### FRONT SIDE

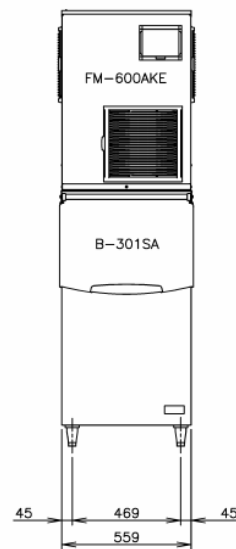

### RIGHT SIDE

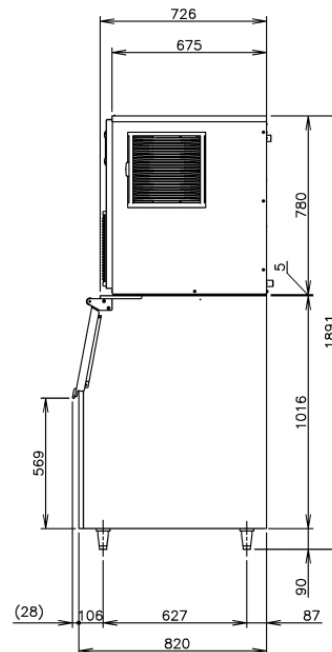

### BACK SIDE

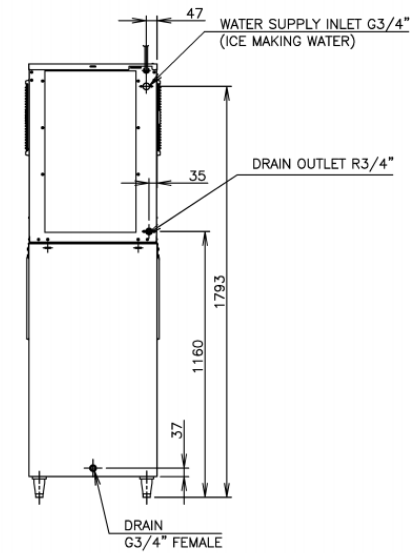

MODEL NAME		FM-600AKE	FM-600AKE-N
ICE SHAPE		Flake	Nugget
DIMENSIONS (MM) (W x D x H)		560 x 700 x 780	
PACKED DIMENSIONS (MM) (W x D x H)		671 x 820 x 971	
WEIGHT (NETT/GROSS)		107 KG / 114 KG	
AMPERAGE / STARTING AMPERAGE		10.5A / 76A	10.8A / 76A
ELECTRICAL CONSUMPTION		1900 W	1950 W
REFRIGERANT CHARGE		R404A	
HEAT REJECTION		3950 W (3396 kcal/h)	3700 W (3181 kcal/h)
ICE PRODUCTION PER 24H	(AT10C/WT10C)	600 KG	530 KG
	(AT21C/WT15C)	540 KG	460 KG
	(AT32C/WT21C)	445 KG	400 KG
WATER CONSUMPTION PER 24H (AT32C/WT21C)		0.48 m <sup>3</sup>	0.43 m <sup>3</sup>
		1.07L / 1KG ICE	1.07L / 1KG ICE

#### • WARRANTY:

Two years parts & labour for entire unit, 3<sup>rd</sup> year on compressor only. Excluding door & exterior damages

#### OPERATING CONDITIONS:

• Voltage Range: 198V-254V • Ambient Temperature: 5°-40°C  
 • Water Supply: 5°-35°C / 0.05-0.8 Mpa / 7.25-116 PSI • AC Supply Voltage: 1/220-240V / 50 Hz

R1