



**HOSHIZAKI**

> **IM-30CNE**  
> **IM-30CNE-25**

daily ice production capacity of up to 28kg



Cube ice is perfectly symmetrical and leaves a good impression with its hard, crystal clear quality that melts very slowly; allowing customers to enjoy their favourite drink longer. The IM series allows more flexibility of application with each range offering ice in variable sizes alongside a design for uncomplicated usage from start to finish.



> IM-30CNE

CUBE ICE MAKER SERIES

## FEATURES

- > smart computer board technology
- > slide-in air filter for easy cleaning
- > LED error indicator for easy diagnosis
- > stainless steel exterior



## UNIQUE ICE PRODUCTION SYSTEM

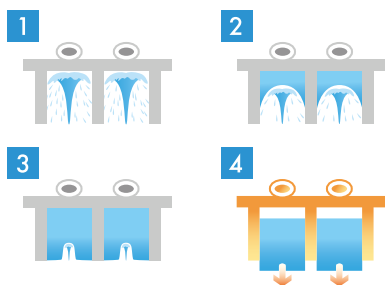

## ICE SIZE

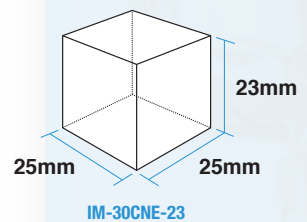
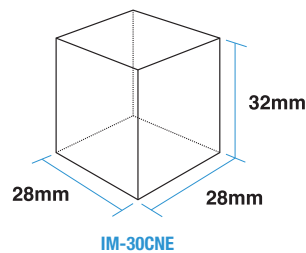

# DIMENSIONS & SPECIFICATION

## CUBE ICE MAKER AIR SYSTEM

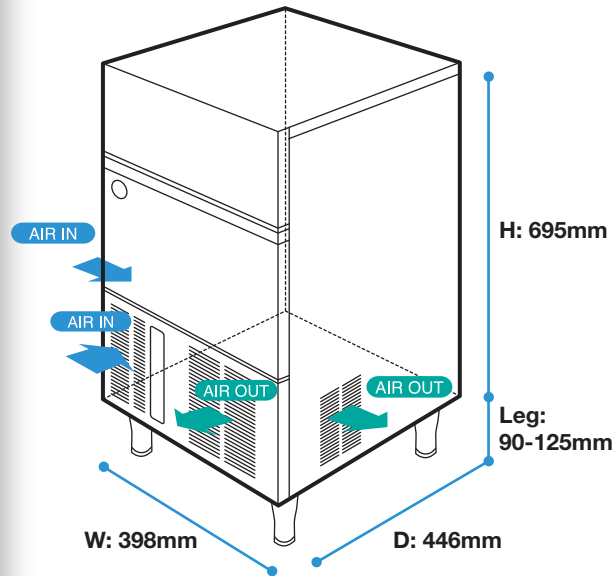

## BACK VIEW

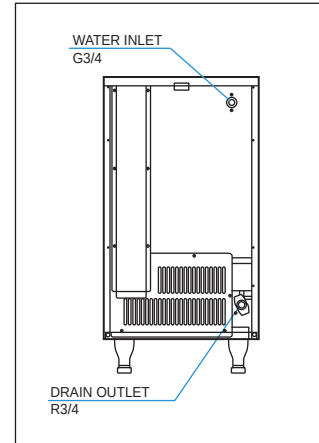

MODEL NAME		IM-30CNE	IM-30CNE-25
ICE DIMENSIONS (MM) (W x D x H)		28 x 28 x 32	25 x 25 x 23
DIMENSIONS (MM) (W x D x H)		Body : 398 x 446 x 695 / Leg Height : 90-125 mm	
PACKED DIMENSIONS (MM) (W x D x H)		505 x 575 x 879	
WEIGHT (NETT/GROSS)		34 KG / 38 KG	
AMPERAGE / STARTING AMPERAGE		1.7A / 10A	
ELECTRICAL CONSUMPTION		270 W	
REFRIGERANT CHARGE		R134a	
HEAT REJECTION (AT32°C/WT21°C)		430 W (370 kcal/h)	
ICE PRODUCTION PER 24H (15MM)	(AT10°C/WT10°C)	28 KG	24 KG
	(AT21°C/WT15°C)	24 KG	20 KG
	(AT32°C/WT21°C)	19 KG	17 KG
WATER CONSUMPTION PER 24H (AT21°C/WT15°C)		0.06 m <sup>3</sup> 2.5L / 1KG ICE	0.07 m <sup>3</sup> 3.5L / 1KG ICE
ICE PRODUCTION (AT21°C/WT15°C)	FREEZE CYCLE TIME	24 MIN	19 MIN
	PER CYCLE	0.4 KG / 18 PCS	0.27 KG / 21 PCS
STORAGE CAPACITY		11.5 KG	

### WARRANTY:

Two years parts & labour for entire unit, 3<sup>rd</sup> year on compressor only. Excluding door & exterior damages

### OPERATING CONDITIONS:

• Voltage Range: 198V-254V • Ambient Temperature: 1°-40°C  
• Water Supply: 5°-35°C / 0.07-0.8 Mpa / 7.25-116 PSI • AC Supply Voltage: 1/220-240V / 50 Hz  
\*60Hz units are available upon request